

Instructions for installation of house switches with control lever – design RETRO

Technical specification:

Type:	DSD10-DPR
Voltage:	250 V AC, 50/60 Hz
Current:	10 AX
SBL rating:	100 W

Installation of switch mounting box:

- Use switch mounting box of min. depth 40 mm
- The switch mounting box must be placed flat (in plane) with the plaster wall. In case of problems with a “sunk” mounting box, the VK1 or VK2 spacer (distance) rings must be used in order to prevent deformation of the fittings when the screws are tightened.
- To install multiple fitting assemblies, it is necessary to use multiple boxes with 71 mm spacing of centres

Switch connection:

- Switches are suitable for connection of Cu wires with 1.5 mm² cross-sections
- Strip the wires in the length of 10 mm and connect the wires according to the marking on the rear side of the switch.
- The specified tightening torque for the screws that secure the wires is 1.2 Nm. It is forbidden to use cordless screwdrivers, which do not allow precise adjustment of the tightening torque.
- Fixing the switch to the mounting box is done via the metal frame using two screws (Fig. 1). The fastening screw must not have a countersunk head.
- After installation of the switch in the box, it is necessary to verify whether the wires are fixed in the fitting terminals correctly and firmly; loose wires should be retightened.
- Place a design frame (ceramic, wood, concrete) and cover on the metal frame of the device and lock it with screws (Fig. 2). When using ceramic frame, tighten screws with a torque of 0,05 Nm – this prevents cracking of the frame due to its fragility
- Supplied screws must not be interchanged with other type

Fig. 1

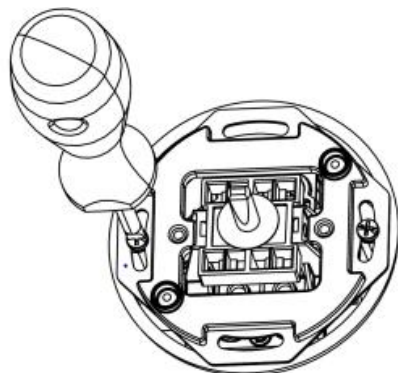
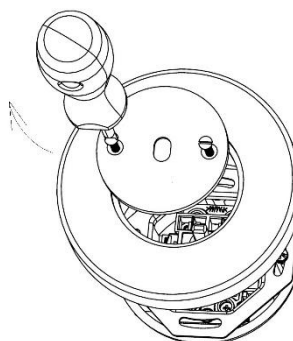

Fig. 2



Maintenance:

The switch device does not require any maintenance!

Switch covers must never be wiped or washed by abrasive cleaning cloths and do not use any aggressive chemicals (petrol, acetone, etc.).

Notice:

Installation and possible disassembly must be entrusted to a person with appropriate electrical qualification. Always disconnect the mains voltage before installation (or dismantling)!

Do not use a broken or damaged device and secure it against use. If the device is not fitted with visible parts, it must not be energized or operated with.

Instructions for installation of house outlet with child protection – design RETRO

Technical specification:

Type: DZ16-1D
Voltage: 250 V AC, 50 / 60 Hz
Current: 16 A

Installation of switch mounting box:

- Use switch mounting box of min. depth 40 mm
- The switch mounting box must be placed flat (in plane) with the plaster wall. In case of problems with a “sunk” mounting box, the VK1 or VK2 spacer (distance) rings must be used in order to prevent deformation of the fittings when the screws are tightened.
- To install multiple fitting assemblies, it is necessary to use multiple boxes with 71 mm spacing of centres

Connecting the outlet:

- The outlets are suitable for connection of Cu wires with cross-sections of 2,5 mm²
- Strip the wires in the length of 10 mm and connect.
- The specified tightening torque for the screws that secure the wires is 1.2 Nm. It is forbidden to use cordless screwdrivers, which do not allow precise adjustment of the tightening torque.
- Fixing the outlet to the mounting box is done via the metal frame with two screws (Fig 1). The fastening screw must not have a countersunk head.
- After installation of the outlet in the box, it is necessary to verify whether the wires are fixed in the fitting terminals correctly and firmly; loose wires should be retightened.
- Place a frame (ceramic, glass, wood, concrete) and cover on the metal frame of the device and lock it with screws (Fig. 2). When using glass frame, tighten screws with a torque of 0,05 Nm – this prevents cracking of the frame due to its fragility
- When using a ceramic frame, it is necessary to place a spacer ring on the socket cover, which is supplied as standard with the socket cover (Fig. 3); do not use a seal with a glass frame.

Fig. 1

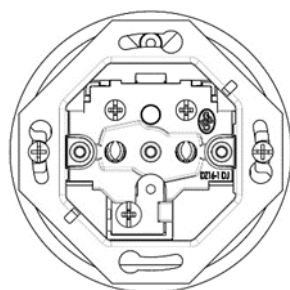

Fig. 2

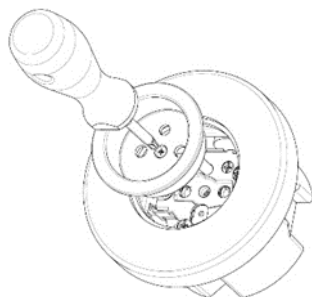
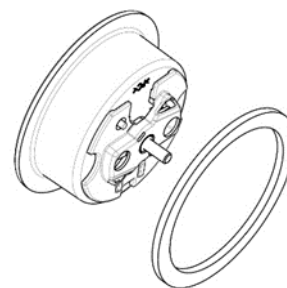
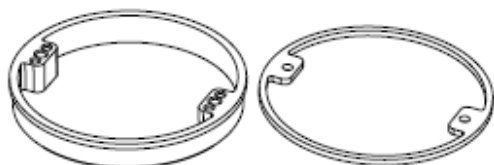

Fig. 3



VK1

VK2



sample of spacer rings VK1 and VK2

Maintenance:

The outlet device does not require any maintenance!

Outlet covers must never be wiped or washed by abrasive cleaning cloths and do not use any aggressive chemicals (petrol, acetone, etc.).

Notice:

Installation and possible disassembly must be entrusted to a person with appropriate electrical qualification. Always disconnect the mains voltage before installation (dismantling)!

Do not use a broken or damaged device and secure it against use. If the device is not fitted with visible parts, it must not be energized or operated with.