

# EN – Instructions for installation of house switches with control lever – design ELEGANT

## Technical specification:

Type:	DSD10-DSE
Voltage:	250 V AC, 50/60 Hz
Current:	10 AX
SBL rating:	100 W

## Installation of switch mounting box:

- Use switch mounting box of min. depth 40 mm
- The switch mounting box must be placed flat (in plane) with the plaster wall.  
In case of problems with a “sunk” mounting box, the VK1 or VK2 spacer (distance) rings must be used in order to prevent deformation of the fittings when the screws are tightened.
- To install multiple fitting assemblies, it is necessary to use multiple boxes with 71 mm spacing of centres

## Switch connection:

- Switches are suitable for connection of Cu wires with 1.5 mm<sup>2</sup> cross-sections
- Strip the wires in the length of 10 mm and connect the wires according to the marking on the rear side of the switch.
- The specified tightening torque for the screws that secure the wires is 1.2 Nm. It is forbidden to use cordless screwdrivers, which do not allow precise adjustment of the tightening torque.
- Fixing the switch to the mounting box is done via the metal frame using two screws (Fig. 1). The fastening screw must not have a countersunk head.
- After installation of the switch in the box, it is necessary to verify whether the wires are fixed in the fitting terminals correctly and firmly; loose wires should be retightened.
- During multiple frame installation must metal carrying frames of devices be joined continuously (without gaps)
- Set the frame onto the switch, insert the plastic connection part and secure it by slightly pushing from the front (Fig. 2)
- Fix the control cover of the switch and check out its correct function (Fig. 3)

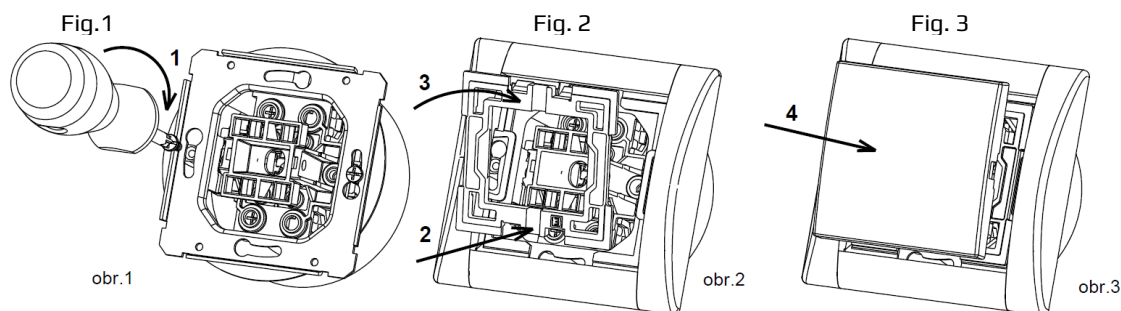

## Disassembly of switches

- Remove the control cover manually by slightly pulling the button at its upper or lower half (Fig. 4)
- Remove the plastic connection part with a screwdriver: turn and release the two locking clips located on either the upper or lower side of the connection part (Fig. 5 and 6)
- Remove the frame and after loosening the two screws, you can take out the switch and dismantle the wires

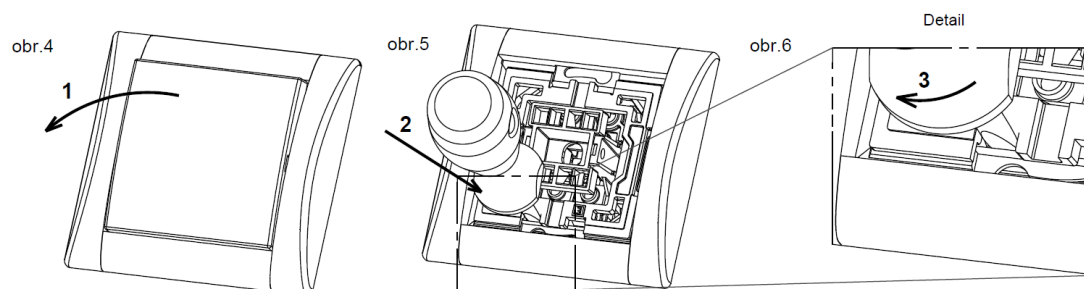

## Maintenance:

The switch device does not require any maintenance!

Switch covers must never be wiped or washed by abrasive cleaning cloths and do not use any aggressive chemicals (petrol, acetone, etc.).

## Notice:

Installation and possible disassembly must be entrusted to a person with appropriate electrical qualification. Always disconnect the mains voltage before installation (or dismantling)!

Do not use a broken or damaged device and secure it against use. If the device is not fitted with visible parts, it must not be energized or operated with.

## EN – Instructions for installation of house outlet with child protection – design ELEGANT

### Technical specification:

Type: DZ16-1D  
Voltage: 250 V AC, 50 / 60 Hz  
Current: 16 A

### Installation of switch mounting box:

- Use switch mounting box of min. depth 40 mm
- The switch mounting box must be placed flat (in plane) with the plaster wall. In case of problems with a “sunk” mounting box, the VK1 or VK2 spacer (distance) rings must be used in order to prevent deformation of the fittings when the screws are tightened.
- To install multiple fitting assemblies, it is necessary to use multiple boxes with 71 mm spacing of centres

### Connecting the outlet:

- The outlets are suitable for connection of Cu wires with cross-sections of 2,5 mm<sup>2</sup>
- Strip the wires in the length of 10 mm and connect.
- The specified tightening torque for the screws that secure the wires is 1.2 Nm. It is forbidden to use cordless screwdrivers, which do not allow precise adjustment of the tightening torque.
- Fixing the outlet to the mounting box is done via the metal frame with two screws (Fig. 1). The fastening screw must not have a countersunk head.
- After installation of the outlet in the box, it is necessary to verify whether the wires are fixed in the fitting terminals correctly and firmly; loose wires should be retightened.
- Set the frame onto the socket (Fig. 2)
- Insert the upper cover part and secure it by tightening the screw (Fig. 3)

Fig. 1

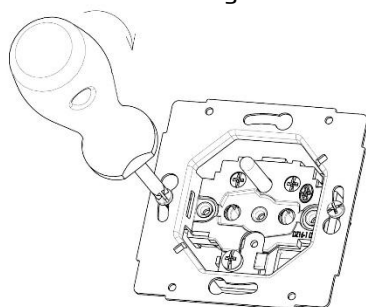

Fig. 2

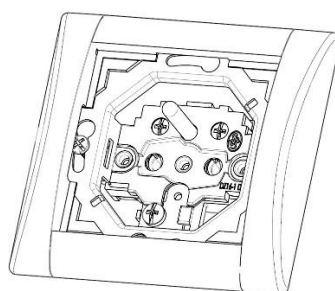
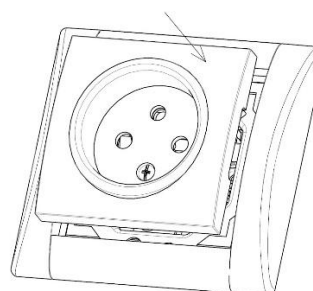

Fig. 3



VK1

VK2

sample of spacer rings VK1 and VK2

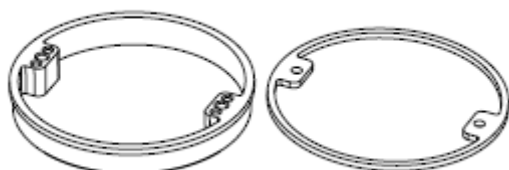

### Maintenance:

The switch device does not require any maintenance!

Switch covers must never be wiped or washed by abrasive cleaning cloths and do not use any aggressive chemicals (petrol, acetone, etc.).

### Notice:

Installation and possible disassembly must be entrusted to a person with appropriate electrical qualification. Always disconnect the mains voltage before installation (or dismantling)!

Do not use a broken or damaged device and secure it against use. If the device is not fitted with visible parts, it must not be energized or operated with.