



CAM SWITCHES



Suitable for safe disconnection



VSR 10 - 16 - 20

VSN 10 - 16 - 20

VSN 25 - 32

VSN 40 - 63 - 75

VSN 80 - 100 - 125 - 150

VSN 250

OBZOR Zlin ... for 50 years always within reach

Production Cooperative was established **fifty years** ago. During this time, OBZOR Zlin has ranked among top producers and distributors of small electromechanical products, automotive parts, metal parts, injection-molded plastic parts and gasket segments.

With the transfer of production of cam switches from the national company SVA in Kutna Hora followed by purchase of license for French **BACO cam switches** in 1970, the company expanded with developers, toolmakers, designers and other professionals and in 1972 started to produce own VS line of cam switches. The biggest customers were national company ROMO Fulnek and TATRAMAT Poprad. Since 1995, OBZOR became an **exclusive representative** of Austrian cam switch producer **Kraus + Naimer** (6 - 2000 A) for Czech Republic and Slovakia. In 2009, the original VS series were upgraded and replaced by a new range of VSN 10 A - 150 A and VSR 10 A - 20 A. Since 2014, VSN series expanded to 250 A. All OBZOR cam switches comply with standard EN 60947-3, Art. 2.3 for safe disconnection, so they can be used as well as disconnectors (designated both on the switch body and the front label).

At present, the Cooperative has its plants in Zlin, Uherske Hradiste, Olomouc and Sumperk, together employing approximately **260 workers**. Company's portfolio also includes medical products, mostly **pill organizers and dental boxes**. Since 2003 began production of **house switches and sockets**.

Our goal is to constantly improve the quality of products and therefore in 1997 we achieved quality system certification according to DIN EN ISO 9001:1995, in 2000 followed by quality management system according to DIN EN ISO 9002 and currently has certificates according to DIN EN ISO 9001: 2009 and ISO 14001: 2005.



Cam switches



House electroinstallation



Medical products



Injection molding



Engineering services



Other services

NEXT GENERATION CAM SWITCHES - VSN, VSR

As purely Czech manufacturer of cam switches with more than 50-year tradition in switches production, we launched the new VSN and VSR product line in 2009.

The product line design has been based on reliable and time-tested technical solutions of the previous VS product line.

Comparing to the previous VS line, the VSN and VSR product lines offer:

- wider range of amperages
- new type of back mounting panel, allowing for mounting the switch both using screws and to a DIN batten
- higher nominal voltage and current values
- higher mechanical and electrical endurance values
- IP20 as a standard protection of connecting terminals and IP65 on the front side
- modern design of control elements, front panels and new protection covers
- square-shaped switch body (former circle-shaped VS switches)
- facile access when connecting conductors into the switch terminals thanks to inclined terminals of VSN 10 - VSN 20 switches
- suitable for safe disconnection
- **5-year warranty for VSN and VSR switches!**
(for VSN and VSR switches delivered after 1. 1. 2011)

All types of extensions and accessories of the original VS product line are supplied in a new design of VSN and VSR product lines, therefore all individual requirements of customers can be accommodated.

The original VS product line was replaced with VSR or VSN cam switches in 2011. However we have available spare parts and accessories for VS 10-16-25-32-63-100: control elements and front panels, locks, rear fitting panel for DIN rail and protection covers. Only while stock lasts.



VSN 10 - 16 - 20



VSR 10 - 16 - 20



VSN 25 - 32



VSN 40 - 63 - 75



VSN 80 - 100 - 125 - 150



VSN 250



Shaft sealing
IP65 in standard model



New front panel and
controller design



VSN 10 - 16 - 20 7



VSR 10 - 16 - 20 10



VSN 25 - 32 15



VSN 40 - 63 - 75 17



VSN 80 - 100 - 125 - 150 19



VSN 250 21



Accessories and special models 23



Protection covers 26



Control elements and front panels 27

	1	2	3	4	5	6	7	8	9	10	11	12
1 - 2	X	X	X	X	X	X	X	X	X	X	X	X
3 - 4					X	X	X	X	X	X	X	X
5 - 6			X								X	X
7 - 8				X								
9 - 10												X
11 - 12	X	X										

Cam switch diagrams 32

V	S	N	-	X	X	X	X	X	X	X	X	A	X	-	V	-	X	X	X
---	---	---	---	---	---	---	---	---	---	---	---	---	---	---	---	---	---	---	---

amperage (type series)	-	switching diagram + angle (switching program)	-	mounting method	-	front panel
------------------------	---	---	---	-----------------	---	-------------

- VSR 10**
- VSR 16**
- VSR 20**
- VSN 10**
- VSN 16**
- VSN 20**
- VSN 25**
- VSN 32**
- VSN 40**
- VSN 63**
- VSN 75**
- VSN 80**
- VSN 100**
- VSN 125**
- VSN 150**
- VSN 250**

XXXX
4-digit scheme is for standard types according to catalogue (chosen by customer)

XXXXXXXX
8-digit scheme is assigned by manufacturer, **used for custom made switch schemes.**

AX
Switching angle is a variable value chosen by customer from scheme list.

V
built-in, panel mounted

***Z**
back mounting, using screws or DIN rail

V22
central mounting in a 22,5mm diameter hole, switch controlled by:
- controller (lever)
- key

ANC
small front panel 50x50 (black)

ANZ
small front panel 50x50 (yellow)

PNC
medium front panel 66x66 (black)

PNZ
medium front panel 66x66 (yellow)

HNC
large front panel 84x84 (black)

HNZ
large front panel 84x84 (yellow)

*switches in K1, K2, SKN and SKV covers are always designed for back mounting - Z

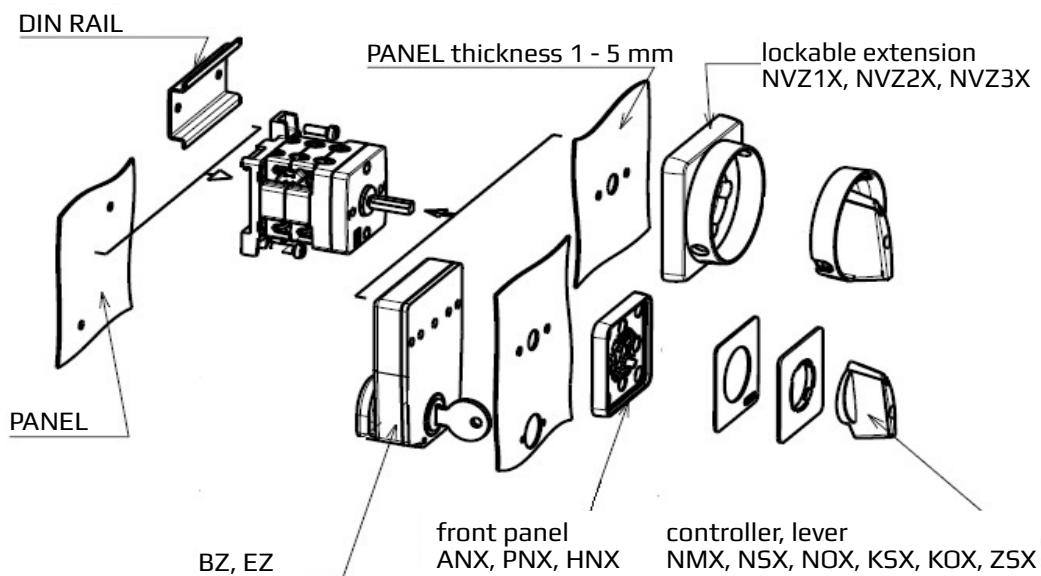

The difference between VSN and VSR 10-20 is in terminals.
 VSR 10-20 terminals are horizontally with the axis of the switch, the screws are tightened perpendicularly to the axis.
 VSN 10-20 terminals are askew to the axis of the switch, the screws are tightened at an angle of approx. 45°
 Technical parametres are identical.
 VSN 25-150 terminals are horizontally with the axis of the switch, the screws are tightened perpendicularly to the axis.

Technical support:
 Tel.: +420 577 195 138, e-mail: ots@obzor.cz

-	S	X	X	X	-	X	X	X	-	X	X	X	X	X	-
---	----------	---	---	---	---	---	---	---	---	---	---	---	---	---	---

-	label designation	-	controller	-	accessories	-	covers
---	--------------------------	---	-------------------	---	--------------------	---	---------------

S001-999

defined by producer
- label designation according to switch position

SPEC

defined by customer
- custom label designation

NMR

arrow small red

NMS

arrow small grey

NMC

arrow small black

NSR

arrow mid-size red

NSS

arrow mid-size grey

NSC

arrow mid-size black

NOR

arrow large red

NOS

arrow large grey

NOC

arrow large black

KSR

lever mid-size red

KSS

lever mid-size grey

KSC

lever mid-size black

KOR

lever large red

KOS

lever large grey

KOC

lever large black

ZSR

lockable arrow red

ZSS

lockable arrow grey

ZSC

lockable arrow

LOCKABLE EXTENSION

NVZ1R

mid-size 66x66 for VSN(R) 10-20 red controller

NVZ1S

mid-size 66x66 for VSN(R) 10-20 grey controller

NVZ1C

mid-size 66x66 for VSN(R) 10-20 black controller

NVZ3R

mid-size 66x66 for VSN(R) 25-150 red controller

NVZ3S

mid-size 66x66 for VSN(R) 25-150 grey controller

NVZ3C

mid-size 66x66 for VSN(R) 25-150 black controller

NVZ2R

large 84x84 for VSN 25-150 red controller

NVZ2S

large 84x84 for VSN 25-150 grey controller

NVZ2C

large 84x84 for VSN 25-150 black controller

BZ - block lock, key can be pulled out only in locked position

EZ - block lock, key can be pulled out also in opened position

REVERSIBLE MECHANISM for VSN(R) 10-20

R21, R81, R812, R78, R32, R78, R32, R7832, R8132, R7821

UNIDIRECTIONAL ROTATION

JO - for VSN 10-20

SPLIT CONTROL

DO - for VSN(R) 10-150

E - switches mounted in parallel

T - switches mounted in series

OK4

VSR 10-20 up to 4 levels

OK6

VSR 10-20 up to 6 levels

OKV

VSR 10-20 up to 6 levels

K1CS

VSN 10-20 up to 4 levels

K1DM

VSN 10-20 up to 3 levels

K1DV

VSN 10-20 up to 6 levels

K2CM

VSN 25-75 up to 2 levels

K2CS

VSN 25-75 up to 4 levels

K2CV

VSN 25-75 up to 6 levels

K2DM

VSN 25-75 up to 3 levels

K2DV

VSN 25-75 up to 6 levels

SKN

VSN 80-150 up to 4 levels

SKV

VSN 250

K2J

cover with circuit breaker VSN 10-75

K2P

cover with fuse switch VSN 10-32

K2PB0

cover with hole for fuse switch VSN 10-75

K2Z

cover with socket (4 or 5 pin) VSN 10-32

K2R

cover with inlet (4 of 5 pin) VSN 10-32

K2XXSG

cover with indicator

NOTE:

Covers supplied with/without PG outlets.

Cam switches technical data (acc. to CSN EN 60947-3)

Type range	VSN 10	VSN 16	VSN 20	VSN 25	VSN 32	VSN 40	VSN 63	VSN 75	VSN 80	VSN 100	VSN 125	VSN 150	VSN 250	
	VSR 10	VSR 16	VSR 20											
Impuls withstand voltage (Uimp)	4 kV	4 kV	4 kV	6 kV	6 kV	6 kV	6 kV	6 kV	6 kV	6 kV	6 kV	6 kV	6 kV	
Isolation voltage (Ui)	690 V	690 V	690 V	690 V	690 V	690 V	690 V	690 V	690 V	690 V	690 V	690 V	690 V	
Thermal current without conductor (Ith)	15 A	20 A	25 A	30 A	40 A	50 A	70 A	90 A	100 A	125 A	150 A	175 A	250 A	
	10 A	16 A	20 A											
Thermal current with conductor (Ithe)	10 A	16 A	20 A	25 A	32 A	40 A	63 A	75 A	80 A	100 A	125 A	150 A	250 A	
	Nominal on-load voltage (Ue)													
Working current (Ie)	400/500 V AC													
	AC21	10 A	16 A	20 A	25 A	32 A	40 A	63 A	75 A	80 A	100 A	125 A	160 A	
	AC23	10 A	16 A	20 A	25 A	30 A	35 A	40 A	45 A	50 A	55 A	60 A	65 A	
AC3	8 A	12 A	14 A	18 A	22 A	25 A	30 A	33 A	35 A	40 A	45 A	50 A	55 A	
Short-circuit switching capacity (Icm)	200 A	230 A	280 A	300 A	450 A	500 A	750 A	1000 A	1000 A	1500 A	2000 A	2500 A	4000 A	
Short-term withstand current (Icw / 1s)	300 A	400 A	500 A	600 A	750 A	900 A	1200 A	1500 A	1500 A	2000 A	2500 A	3000 A	4500 A	
Working frequency	50 Hz													
Conductor diameter in mm (under the screw), only for Copper conductors	1 - 4 mm ²													
Maximum number of switching positions	4 - 10 mm ²													
Maximum number of levels	12													
Maximum number of contacts	12													
Control shaft size	24													
Electrical endurance in AC3 and AC23 classes acc. to CSN EN 60947-3 (number of cycles)	5 x 5 mm													
	6 x 6 mm													
	150 000 for AC23	100 000 for AC23	80 000 for AC23	70 000 for AC23	60 000 for AC23	40 000 for AC23	30 000 for AC23	30 000 for AC23	10 000 for AC23	15 000 for AC23	12 000 for AC23	6 000 for AC23	5 000 for AC23	200 for all categories
	100 000 for AC3	70 000 for AC3	50 000 for AC3	50 000 for AC3	40 000 for AC3	30 000 for AC3	20 000 for AC3	20 000 for AC3	6 000 for AC3	100 000	100 000	100 000	100 000	1 400
Mechanical endurance (number of cycles)	250 000													
Protection of cam switch	IP 20													
	From Front													
Maximum switching frequency / h	IP 65													
Weather resistance	900													
Mounting position	any													
Connection screw	torx Nr. 15													
Maximum tightening torque	1 Nm													
Dimensions	43 x 43 mm													
Front mounting pitch	30 mm													
Max. length of conductor stripping	10 mm													

All cam switches meet the requirements of CSN EN 60 947-3, Section 2.3 - disconnectors.

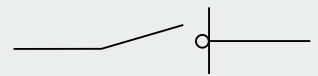

All cam switches can be used for nominal voltage levels of 400 V AC and 500 V AC.

Requirement for application of VSN 10 - VSN 75 in the 500 V AC network must be declared in the order..

CAM SWITCHES

for safe disconnection according to CSN EN 60947-3 article 2.3

10 A

16 A

20 A



Cam switches, front mounted (embedded)

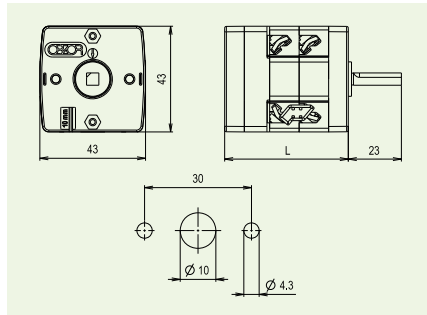

Number of levels	Number of switching systems	Length L (mm)
1	1 - 2	38,3
2	3 - 4	50,3
3	5 - 6	62,3
4	7 - 8	74,3
5	9 - 10	86,3
6	11 - 12	98,3
7	13 - 14	110,3
8	15 - 16	122,3
9	17 - 18	134,3
10	19 - 20	146,3
11	21 - 22	158,3
12	23 - 24	170,3

Length of the control shaft can be extended at customer's discretion in 12 mm sections.

Cam switches, central mounted

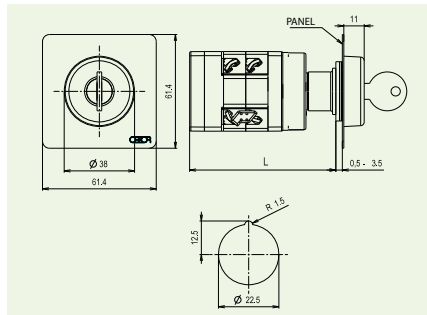

Note: with key control, the switches can be applied only up to 4 levels.

Number of levels	Number of switching systems	Length L (mm)
1	1 - 2	67
2	3 - 4	79
3	5 - 6	91
4	7 - 8	103
5	9 - 10	115
6	11 - 12	127
7	13 - 14	139
8	15 - 16	151
9	17 - 18	163
10	19 - 20	175
11	21 - 22	187
12	23 - 24	194

VSN 10-16-20 switches with central mounting to the opening with diameter of 22.5 mm are available in two models:

- with key control
- with arrow control

At key controlled switches, the key can be removed in all positions when switching angle equals to 45° and 90°.

Cam switches, back mounted using screws

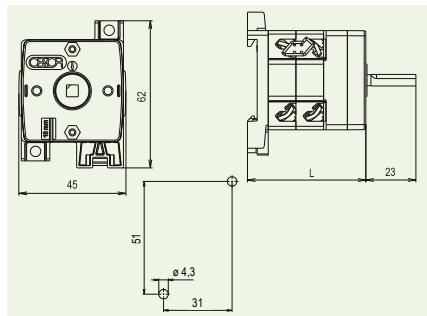

Number of levels	Number of switching systems	Length L (mm)
1	1 - 2	39,3
2	3 - 4	51,3
3	5 - 6	63,3
4	7 - 8	75,3
5	9 - 10	87,3
6	11 - 12	99,3
7	13 - 14	111,3
8	15 - 16	123,3
9	17 - 18	135,3
10	19 - 20	147,3
11	21 - 22	159,3
12	23 - 24	171,3

Length of the control shaft can be extended at customer's discretion in 12 mm sections.

Cam switches, back mounted on DIN batten

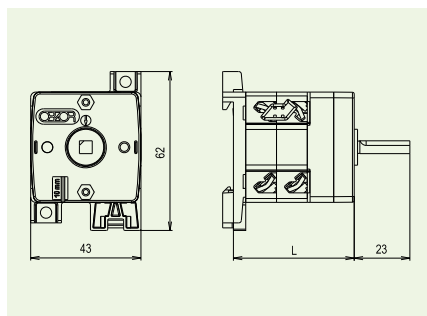

Number of levels	Number of switching systems	Length L (mm)
1	1 - 2	35,1
2	3 - 4	47,1
3	5 - 6	59,1
4	7 - 8	71,1
5	9 - 10	83,1
6	11 - 12	95,1
7	13 - 14	107,1
8	15 - 16	119,1
9	17 - 18	131,1
10	19 - 20	143,1
11	21 - 22	155,1
12	23 - 24	167,1

With the back mounted extension, VSN can be fixed using screws or to the batten of 35 × 7,5 mm according to DIN EN 50022. Length of the control shaft can be extended at customer's discretion in 12 mm sections.

Back mounting panel for pro VSN 10 - 16 - 20

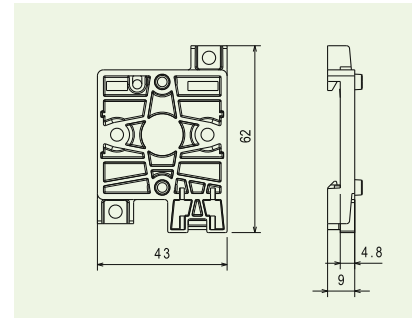

Universal model for both mounting using screws and on a DIN batten.

One-way turning cam switches - JO type



One-way turning can be carried out only for VSN 10-16-20 under the switching angle of 45° a 90° with front or back mounting.
The device prevents reverse turning of the switch. Length of the switch is increased by 12 mm.

Automatic reverse movement cam switches - R-type

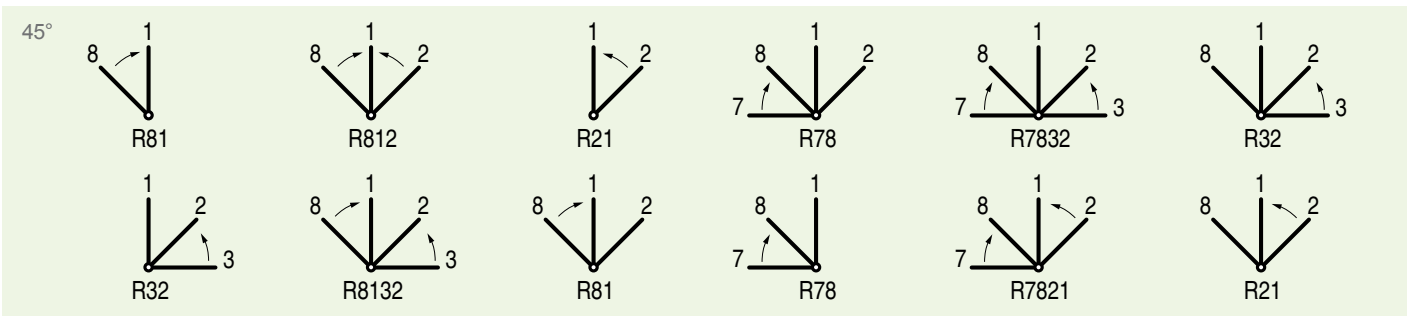

VSN 10 - 16 - 20 cam switch can be fitted with automatic reverse movement device (for pulse switching).

Automatic reverse movement can be applied to switches up to 4 switching levels, i. e. 8 switching circuits. Other applications should be consulted with the manufacturer.

R81 identification defines automatic reverse movement from position 8 to position 1. R812 identification indicates automatic reverse movement from position 8 to position 1 and from position 2 to position 1.

Reverse positions are marked with arrows, all other positions are locked.

Length of the switch L is increased by 12 mm.

Cam switches, front mounted (embedded)

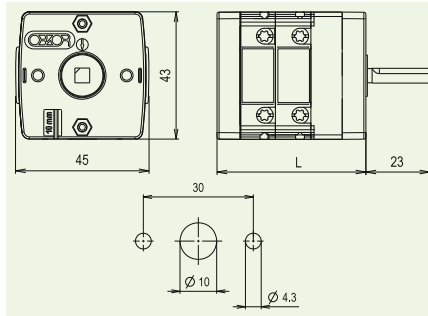

Number of levels	Number of switching systems	Length L (mm)
1	1 - 2	34,5
2	3 - 4	46,5
3	5 - 6	58,5
4	7 - 8	70,5
5	9 - 10	82,5
6	11 - 12	94,5
7	13 - 14	106,5
8	15 - 16	118,5
9	17 - 18	130,5
10	19 - 20	142,5
11	21 - 22	154,5
12	23 - 24	166,5

Length of the control shaft can be extended at customer's discretion in 12mm sections.

Cam switches, central mounted

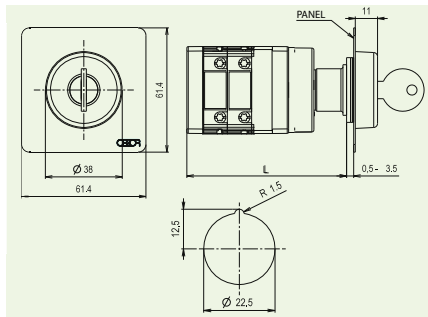

Note: with key control, the switches can be applied only up to 4 levels.

Number of levels	Number of switching systems	Length L (mm)
1	1 - 2	67
2	3 - 4	79
3	5 - 6	91
4	7 - 8	103
5	9 - 10	115
6	11 - 12	127
7	13 - 14	139
8	15 - 16	151
9	17 - 18	163
10	19 - 20	175
11	21 - 22	187
12	23 - 24	194

VSR 10-16-20 switches with central mounting to the opening with diameter of 22.5 mm are available in two models:

- with key control
- with arrow control

Key controlled switches - key can be removed in all positions when switching angle equals to 45° and 90°.

Cam switches, back mounted using screws

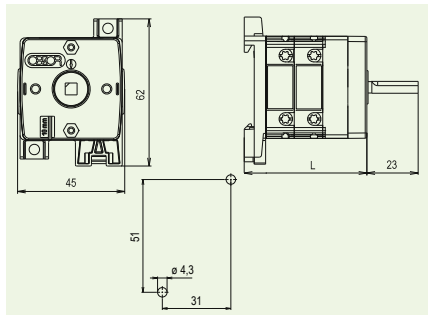

Number of levels	Number of switching systems	Length L (mm)
1	1 - 2	39,3
2	3 - 4	51,3
3	5 - 6	63,3
4	7 - 8	75,3
5	9 - 10	87,3
6	11 - 12	99,3
7	13 - 14	111,3
8	15 - 16	123,3
9	17 - 18	135,3
10	19 - 20	147,3
11	21 - 22	159,3
12	23 - 24	171,3

Length of the control shaft can be extended at customer's discretion..

Cam switches, back mounted on DIN batten

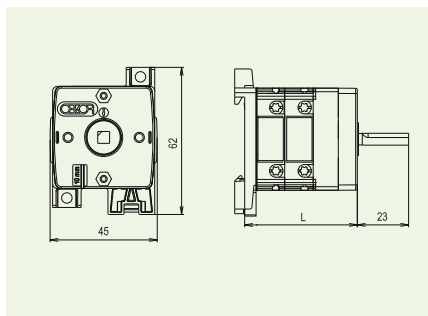

Number of levels	Number of switching systems	Length L (mm)
1	1 - 2	35,1
2	3 - 4	47,1
3	5 - 6	59,1
4	7 - 8	71,1
5	9 - 10	83,1
6	11 - 12	95,1
7	13 - 14	107,1
8	15 - 16	119,1
9	17 - 18	131,1
10	19 - 20	143,1
11	21 - 22	155,1
12	23 - 24	167,1

With the back mounted extension, VSR can be fixed using screws or to the batten of 35 × 7,5 mm according to DIN EN 50022. Length of the control shaft can be extended at customer's discretion.

Back mounting panel for VSR 10 - 16 - 20

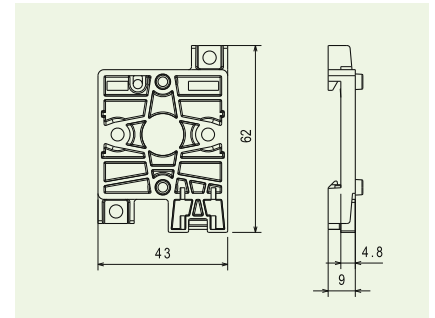

Universal model for both mounting using screws and on a DIN batten.

Automatic reverse movement cam switches - R-type

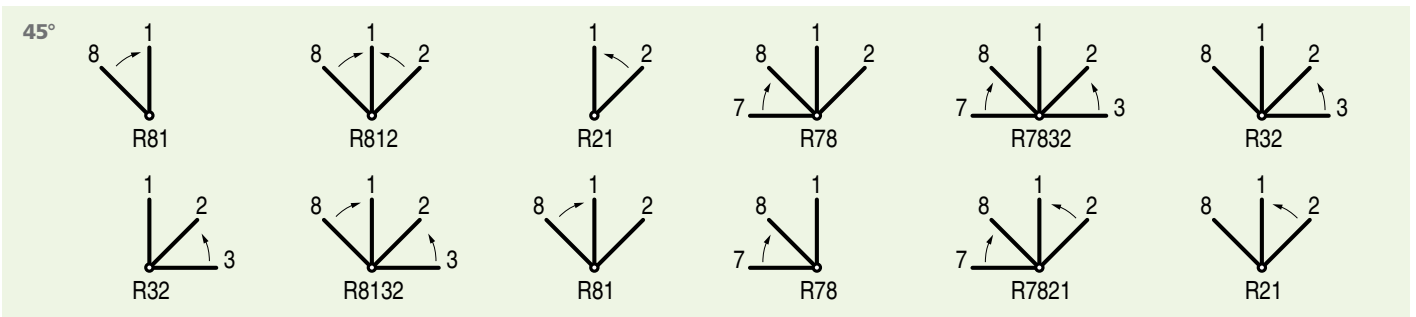

VSN 10 - 16 - 20 cam switch can be fitted with automatic reverse movement device (for pulse switching).

Automatic reverse movement can be applied to switches up to 4 switching levels, i. e. 8 switching circuits. Other applications should be consulted with the manufacturer.

R81 identification defines automatic reverse movement from position 8 to position 1. R812 identification indicates automatic reverse movement from position 8 to position 1 and from position 2 to position 1.

Reverse positions are marked with arrows, all other positions are locked.

Length of the switch L is increased by 12 mm.

Protection cover K1CS

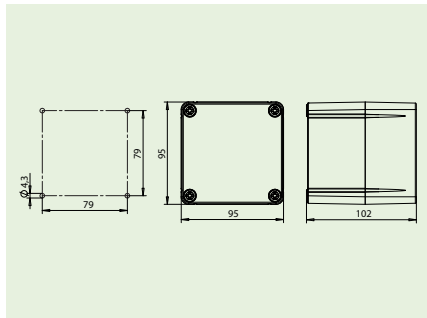

PROTECTION COVER VSN 10 - 16 - 20
VSR 10 - 16 - 20

K1CS for VSN (VSR) 10 - 16 - 20
up to max. 4 levels

- IP 65, installation on vertical surface
- for switches without additional devices (switch with indicator, block lock switches, ...)
- outlets placed in the upper and lower part of the cover (front view) max. 2 x PG 16 (1 x PG 21)
- cover fitted with N, PE conductors terminals
- plastic material - suitable also for mounting on materials of B, C1, C2 flammability grades

Protection cover K1D

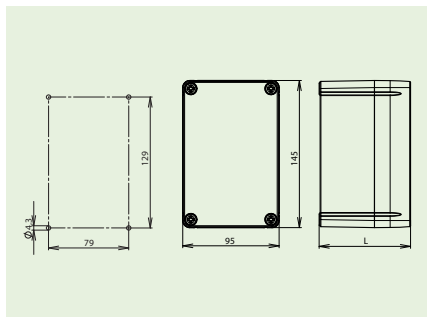

Cover	L (mm)
K1DM	90
K1DV	127

PROTECTION COVER VSN 10 - 16 - 20
VSR 10 - 16 - 20

Produced in two sizes:

1. K1DM for VSN (VSR) 10 - 16 - 20 do max. 3 levels
2. K1DV for VSN (VSR) 10 - 16 - 20 do max. 6 levels

- IP 65, installation on vertical surface
- for switches with addition
- outlets placed in the upper and lower part of the cover max. 2 x PG 16 (1 x PG 21)
- cover fitted with N, PE conductors terminals
- plastic material - suitable also for mounting on materials of B, C1, C2 flammability grades

Protection cover K2D

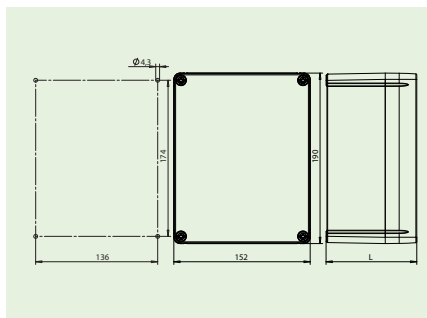

Cover	L (mm)
K2DM	101
K2DV	168

PROTECTION COVER VSN 10 - 16 - 20
VSR 10 - 16 - 20

Produced in two sizes:

1. K2DM for VSN (VSR) 10 - 16 - 20 up to max. 4 levels
2. K2DV for VSN (VSR) 10 - 16 - 20 up to max. 9 levels

- IP 65, installation on vertical surface
- for switches with additional devices (switch with indicator, block lock switches, ...)
- outlets placed in the upper and lower part of the cover (front view) max. 2 x PG 29
- cover fitted with N, PE conductors terminals
- plastic material - suitable also for mounting on materials of B, C1, C2 flammability grades

Cylindrical protection cover OKV

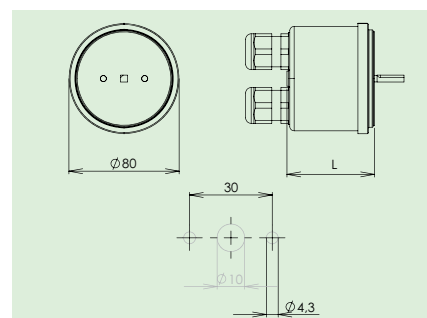

CYLINDRICAL PROTECTION COVER
VSN 10 - 16 - 20

- IP 65, installation on vertical surface
- for switches without addition
- Outlets placed in the back - 2x pg 16
- plastic material

Number of levels	Length L (mm)
1	68
2	80
3	92
4	104
5	116

Protection cover OK4

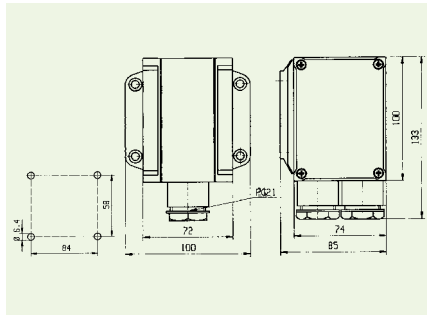

PROTECTION COVER VSN 10 - 16 - 20
VSR 10 - 16 - 20

OK4 for VSN (VSR) 10 - 16 - 20
up to max. 4 levels

- IP 54, installation on horizontal surface
- 2 x PG 21 outlets, standardly embedded on the back of the cover
- cover fitted with N, PE conductors terminals
- plastic material

Protection cover OK6

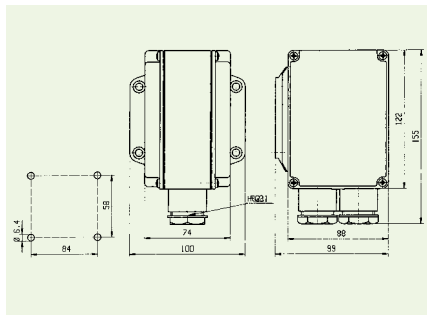

PROTECTION COVER VSN 10 - 16 - 20
VSR 10 - 16 - 20

OK6 for VSN (VSR) 10 - 16 - 20
up to max. 6 levels

- IP 54, installation on horizontal surface
- 2 x PG 21 outlets, standardly embedded on the back of the cover
- cover fitted with N, PE conductors terminals
- for switches with additional devices (block lock switches, max. up to 2 levels, cover fitted for vertical surface installation, outlets placed in the bottom of the cover)
- plastic material



ZEMINISPOL



MULTIPLI



EMERGENCY STOP



CAM SWITCHES

for safe disconnection according to CSN EN 60947-3 article 2.3

25 A

32 A



Cam switches, front mounted (embedded)

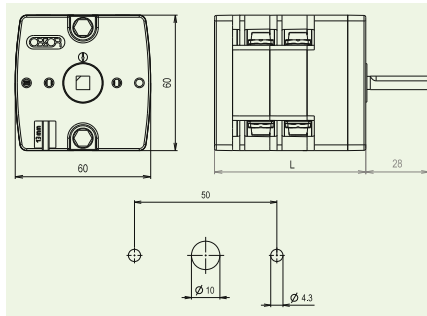

Number of levels	Number of switching systems	Length L (mm)
1	1 - 2	50,5
2	3 - 4	67
3	5 - 6	83,5
4	7 - 8	100
5	9 - 10	116,5
6	11 - 12	133
7	13 - 14	149,5
8	15 - 16	166
9	17 - 18	182,5
10	19 - 20	199
11	21 - 22	215,5
12	23 - 24	232

Length of the control shaft can be extended at customer's discretion in 16.5 mm sections.

Cam switches, back mounted on screws

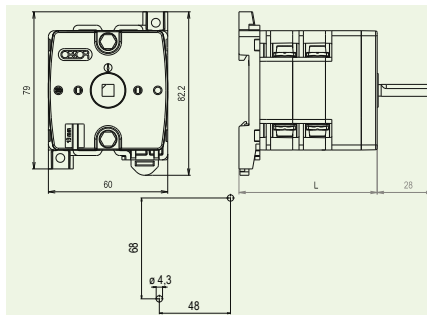

Number of levels	Number of switching systems	Length L (mm)
1	1 - 2	53
2	3 - 4	69,5
3	5 - 6	86
4	7 - 8	102,5
5	9 - 10	119
6	11 - 12	135,5
7	13 - 14	152
8	15 - 16	168,5
9	17 - 18	185
10	19 - 20	201,5
11	21 - 22	218
12	23 - 24	234,5

Length of the control shaft can be extended at customer's discretion in 16.5 mm sections.

Cam switches, back mounted on DIN batten

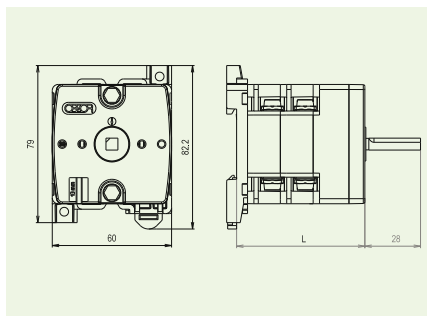
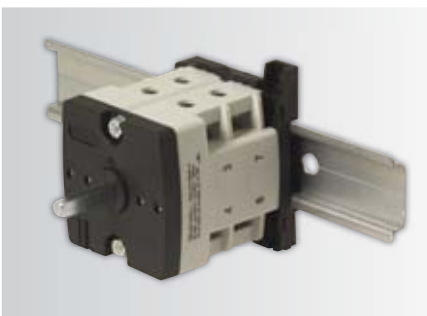

Number of levels	Number of switching systems	Length L (mm)
1	1 - 2	48
2	3 - 4	64,5
3	5 - 6	81
4	7 - 8	97,5
5	9 - 10	114
6	11 - 12	130,5
7	13 - 14	147
8	15 - 16	163,5
9	17 - 18	180
10	19 - 20	196,5
11	21 - 22	213
12	23 - 24	229,5

With the back mounted extension, VSN can be fixed using screws or to the batten of 35 × 7,5 mm according to DIN EN 50022. Length of the control shaft can be extended at customer's discretion in 16.5 mm sections.

CAM SWITCHES

for safe disconnection according to CSN EN 60947-3 article 2.3

40 A

63 A

75 A



Cam switches, front mounted (embedded)

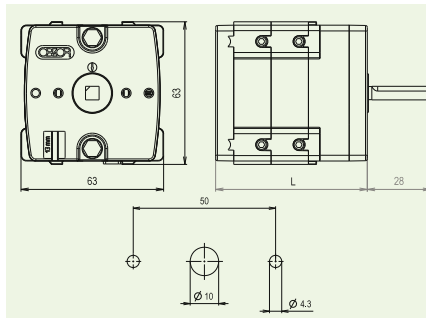

Number of levels	Number of switching systems	Length L (mm)
1	1 - 2	50,5
2	3 - 4	67
3	5 - 6	83,5
4	7 - 8	100
5	9 - 10	116,5
6	11 - 12	133
7	13 - 14	149,5
8	15 - 16	166
9	17 - 18	182,5
10	19 - 20	199
11	21 - 22	215,5
12	23 - 24	232

Length of the control shaft can be extended at customer's discretion in 16.5 mm sections.

Cam switches, back mounted on screws

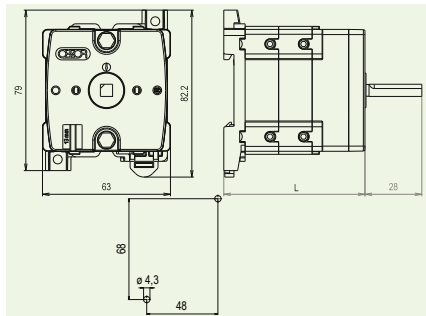

Number of levels	Number of switching systems	Length L (mm)
1	1 - 2	53
2	3 - 4	69,5
3	5 - 6	86
4	7 - 8	102,5
5	9 - 10	119
6	11 - 12	135,5
7	13 - 14	152
8	15 - 16	168,5
9	17 - 18	185
10	19 - 20	201,5
11	21 - 22	218
12	23 - 24	234,5

Length of the control shaft can be extended at customer's discretion in 16.5 mm sections.

Cam switches, back mounted on DIN batten

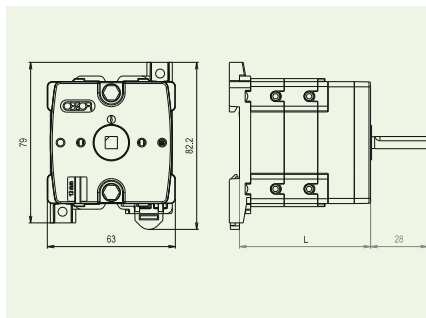

Number of levels	Number of switching systems	Length L (mm)
1	1 - 2	48
2	3 - 4	64,5
3	5 - 6	81
4	7 - 8	97,5
5	9 - 10	114
6	11 - 12	130,5
7	13 - 14	147
8	15 - 16	163,5
9	17 - 18	180
10	19 - 20	196,5
11	21 - 22	213
12	23 - 24	229,5

With the back mounted extension, VSN can be fixed using screws or to the batten of 35 × 7,5 mm according to DIN EN 50022. Length of the control shaft can be extended at customer's discretion in 16.5 mm sections.

VSN 75 switches are available only without the contact jumper wires.

To fulfil IP20 requirements, all idle terminals of VSN 40-75 cam switches shall be covered with plugs as standard.

CAM SWITCHES

for safe disconnection according to CSN EN 60947-3 article 2.3

80 A
100 A
125 A
150 A



Cam switches, front mounted (embedded)

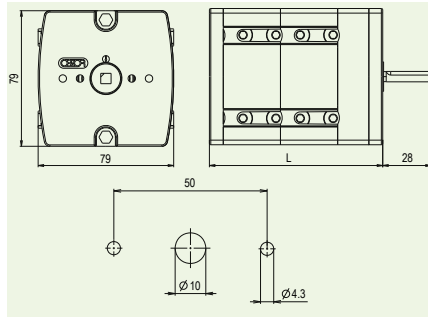

Number of levels	Number of switching systems	Length L (mm)
1	1 - 2	67
2	3 - 4	100
3	5 - 6	133
4	7 - 8	166
5	9 - 10	199
6	11 - 12	232

Length of the control shaft can be extended at customer's discretion in 16.5 mm sections.

Cam switches, back mounted on screws

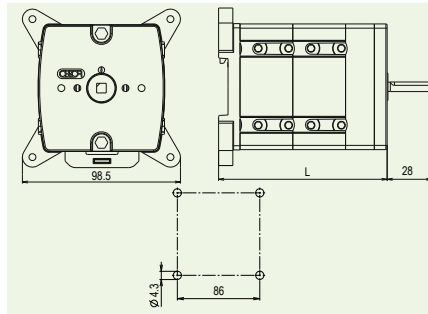

Number of levels	Number of switching systems	Length L (mm)
1	1 - 2	72.5
2	3 - 4	105.4
3	5 - 6	138.4
4	7 - 8	171.4
5	9 - 10	204.4
6	11 - 12	237.4

Length of the control shaft can be extended at customer's discretion in 16.5 mm sections.

Cam switches, back mounted on DIN batten

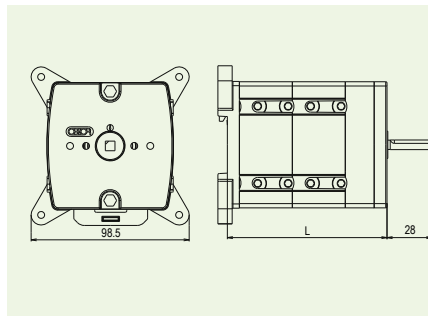

Number of levels	Number of switching systems	Length L (mm)
1	1 - 2	65.5
2	3 - 4	99.5
3	5 - 6	132.5
4	7 - 8	165.5
5	9 - 10	198.5
6	11 - 12	231.5

With the back mounted extension, VSN can be fixed using screws or to the batten of 35 × 7,5 mm according to DIN EN 50022. Length of the control shaft can be extended at customer's discretion in 16.5 mm sections.

To fulfil IP20 requirements, all idle terminals of VSN 80 - 150 cam switches shall be covered with plugs as standard.

CAM SWITCHES

for safe disconnection according to CSN EN 60947-3 article 2.3

250 A



Cam switches, front mounted (embedded)

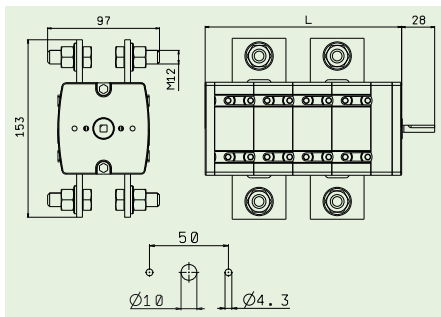

Number of levels	Number of switching systems	Length L (mm)
1	1 - 2	100
2	3 - 4	166
3	5 - 6	232

Length of the control shaft can be extended at customer's discretion in 16.5 mm sections.

Cam switches, back mounted on screws

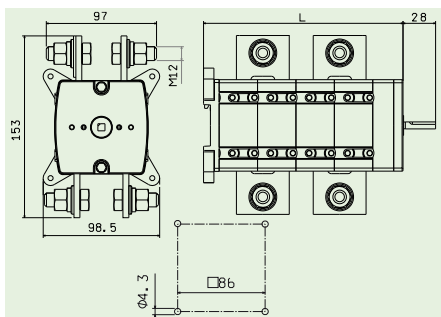

Number of levels	Number of switching systems	Length L (mm)
1	1 - 2	105,4
2	3 - 4	171,4
3	5 - 6	237,4
4	7 - 8	303,4

Length of the control shaft can be extended at customer's discretion in 16.5 mm sections.

Protection of connecting terminals IP 00.

Cam switches, with block locks - BZ type

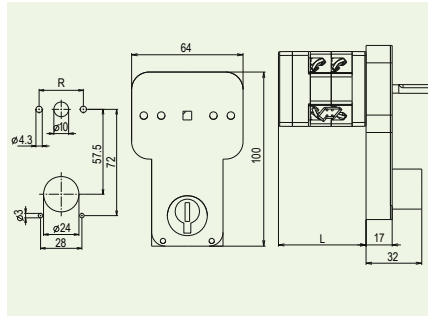

R	Type range
30 mm	VSN, VSR 10 - 16 - 20
50 mm	VSN 25 - 250

At VSN 10 - 150, VSR 10 - 16 - 20 cam switches, the block lock of BZ type is capable of locking at the switch switching angle of 45 Dgr or 90 Dgr one (any) position, or all positions. At other switching angles, only a position of 12, 3, 6, or 9 o'clock may be locked. The key can be removed only when the switch is in the locked position.

Block lock cam switches of BZ type are available:
a) with lock inserts for various number of keys (BZX)
a) with lock inserts for the same number of the key (BZY)
Block locks of BZ type are not available for the central mounted cam switches.

Block lock cam switches - EZ type

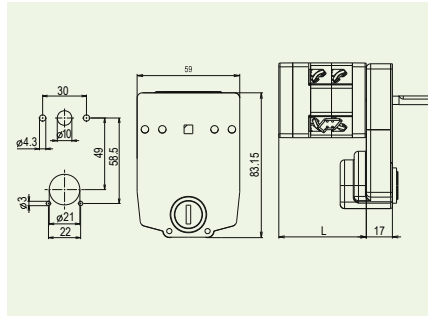

R	Type range
30 mm	VSN, VSR 10 - 16 - 20
50 mm	VSN 25 - 75

EZ type block locks can be used under the same conditions as BZ block locks. The only difference is that the key can be removed from the lock also in the switch unlock position.

Cam switches, with split control - DO type

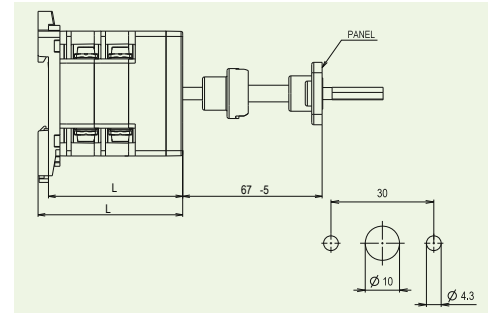
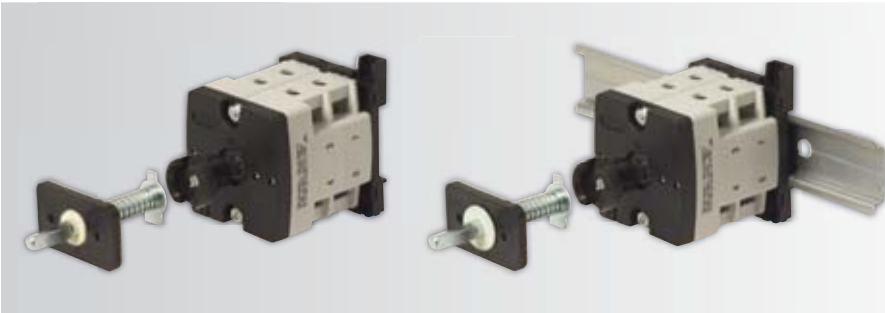

The split control cam switch can be mounted so that the control element is fixed on the removable or turning panel, whilst the cam switch is firmly fixed in the cabinet or switchboard. The cam switch can be back mounted. Distance of the front panel from the cam switch body is 62 - 67 mm.

Cam switches, mechanically mounted in series - T type

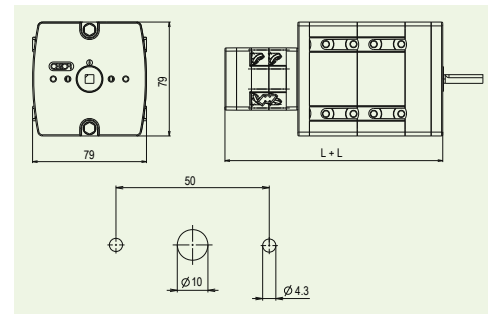

By connecting two switches in series to the common shaft, two cam switches of various amperages and sizes can be simultaneously controlled, e. g. common switching of power and control contacts. Control contacts of an additional switch can be switched in advance, or with delay compared to the main contacts.

Cam switches, mechanically mounted in parallel - E type

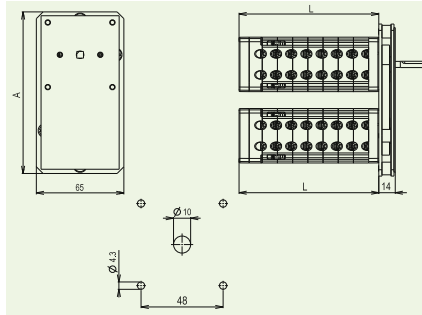

Type range	A (mm)
VSN 10 - 16 - 20 + VSN 10 - 16 - 20	120
VSR 10 - 16 - 20 + VSR 10 - 16 - 20	120
VSN 25 - 32 + VSN, VSR 10 - 16 - 20	120
VSN 40 - 63 - 75 + VSN, VSR 10 - 16 - 20	147
VSN 25 - 75 + VSN 25 - 75	147

Various switching problems can be solved with an extension connecting two cam switches in parallel. For instance, in case the mounting space is limited, two shorter switches can be used instead of one longer, or in case the switching program requires more than 24 contacts (switching levels), switching can be split between cam switches. In both cases, the switches are controlled via one control arrow.

Additional connecting terminal VSN 40 - 150

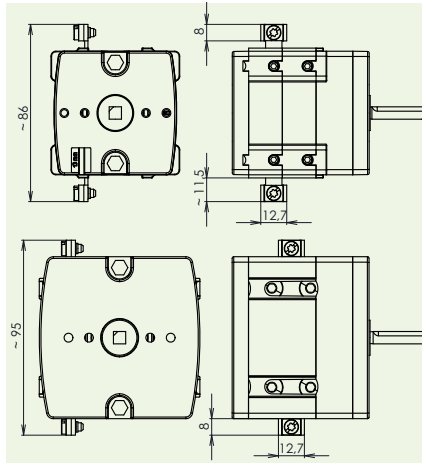

Connecting terminal allows connection of conductors with diameter 1 - 4 mm².
- protection IP 00
- supplied only as a spare part

Additional connecting terminal for cable lug VSN 80 - 150

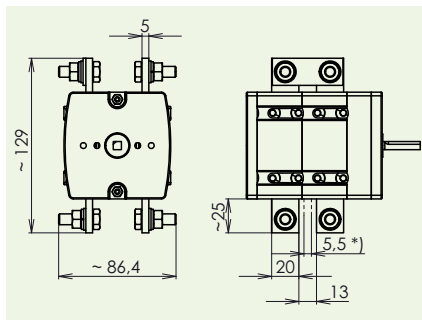

Additional connecting terminal allows connection of conductors using cable lug endings and M8 screws.
- supplied only as a spare part
- protection IP 00

new

*) - minimum allowed distance between cable lugs that must be kept when mounting.
For mezzanine connection of terminals using additional connecting terminals, it is necessary to use a special connectors that need to be ordered in the same amount as the number of standard connectors between levels of the switch.

Cam switches with front panels 45 x 52 mm

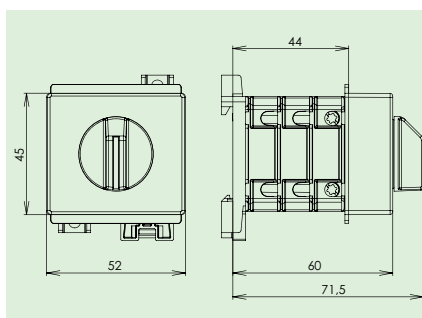

VSN, VSR 10 - 16 - 20 cam switches up to 3 switching levels can be mounted with the front panel of 45 x 52 mm to a range of module devices with the module thickness of 17,5 mm. To keep the modul device height (44 mm), the switches are fitted with switching levels with no contacts, if needed.

In case more switching levels are needed, the total length of 44 mm will be increased by 12 mm per each additional level. In such a case, the switches are supplied with a standard NM control lever.

Back mounting panel for VSN 25 - 75

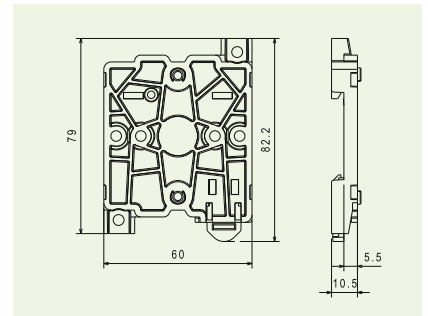

Universal model for both mounting using screws and on a DIN batten.

Back mounting panel for VSN 80 - 100 - 125 - 150

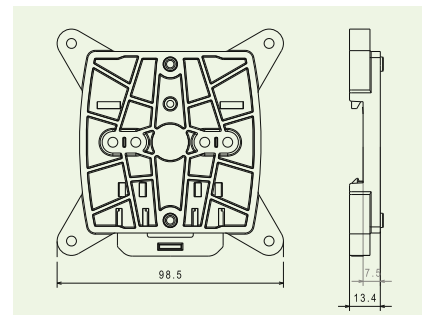

Universal model for both mounting using screws and on a DIN batten.

Back mounting panel for VSN 250

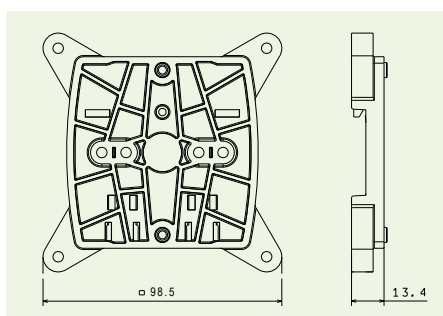

Universal model for mounting using screws.

Protection cover K2C

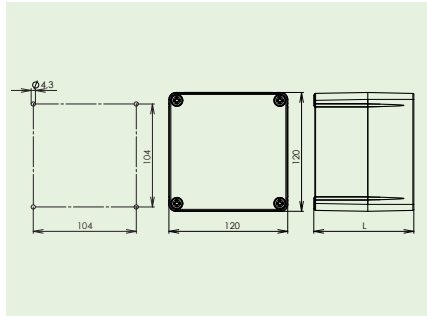

Cover	L (mm)
K2CM	101
K2CS	134
K2CV	168

PROTECTION COVER VSN 25 - 75

Produced in three sizes:

1. K2CM for VSN 25 - 75 max. up to 2 levels
 2. K2CS for VSN 25 - 75 max. up to 4 levels
 3. K2CV for VSN 25 - 75 max. up to 6 levels
- IP 65, installation on vertical surface
 - for switches without auxiliaries
 - outlets placed in the upper and lower part of the cover max. 2 x PG 21 (1 x PG 29)
 - cover fitted with N, PE conductors terminals
 - plastic material - suitable also for mounting on materials of B, C1, C2 flammability grades

Protection cover K2D

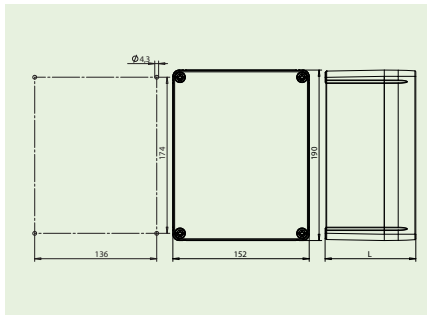

Cover	L (mm)
K2DM	101
K2DV	168

PROTECTION COVER VSN 25 - 75

Produced in two sizes:

1. K2DM for VSN 25 - 75 up to max. 3 levels
 2. K2DV for VSN 25 - 75 up to max. 6 levels
- IP 65, installation on vertical surface
 - for switches with additional devices (switch with indicator, block lock switches, ...)
 - outlets placed in the upper and lower part of the cover (front view) max. 2 x PG 29
 - cover fitted with N, PE conductors terminals
 - plastic material - suitable also for mounting on materials of B, C1, C2 flammability grades

Protection cover SKN

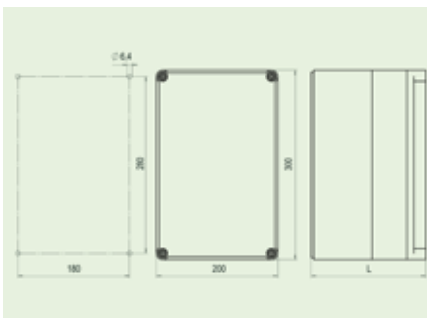

Cover	L (mm)
number of switch levels 2	132
number of switch levels 3	187
number of switch levels 4	242

PROTECTION COVER VSN 80 - 150

SKN for VSN 80 - 150 max. up to 3 levels.

- IP 65, installation on vertical surface
- for switches with additional devices
- outlets placed in the upper and lower part of the cover (front view) max. 2x PG 36
- cover fitted with N, PE conductors terminals
- plastic material

Protection cover SKV

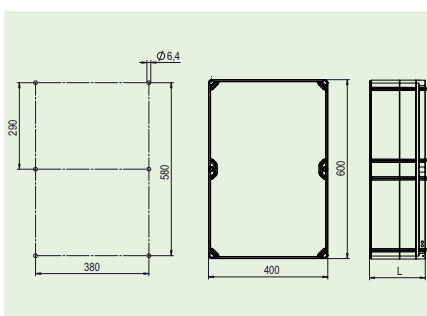

Number of levels	L (mm)
1	132
2	242
3	297

PROTECTION COVER VSN 250

SKV for VSN 250 max. up to 3 levels.

- IP 65, installation on vertical surface
- outlets placed in the upper and lower part of the cover (front view) max. 2 x PG 48
- cover fitted with N, PE conductors terminals
- plastic material

Controller and front panel - small

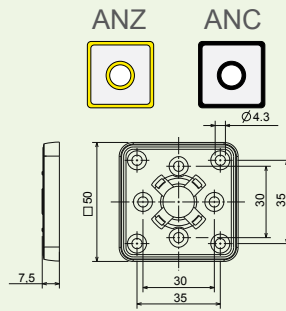

NMR NMS NMC

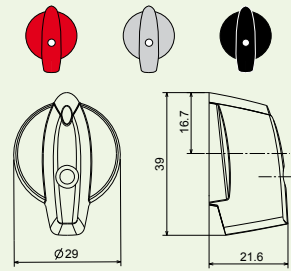

Controller and front panel - medium

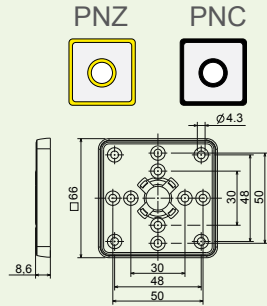

NSR NSS NSC

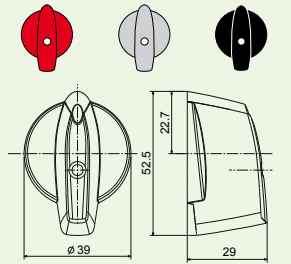

Controller and front panel - large

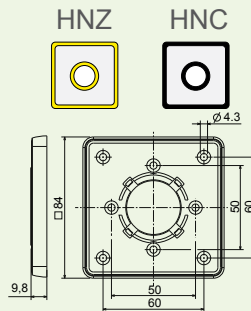

NOR NOS NOC

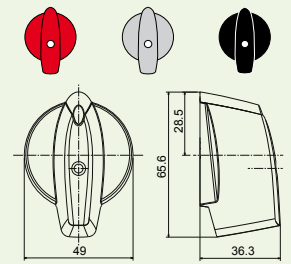

Controller (lever) and front panel - medium

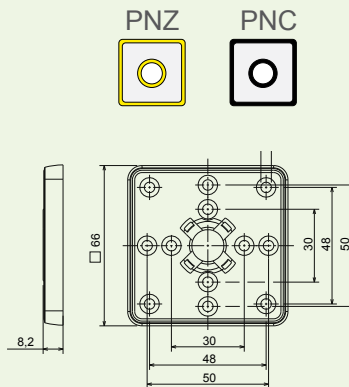

KSR KSS KSC

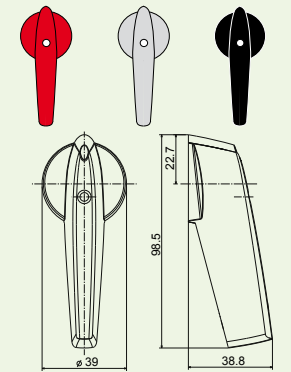

Controller (lever) and front panel - large

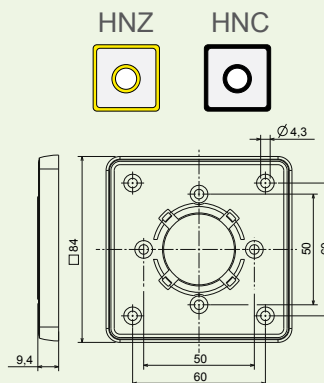

KOR KOS KOC

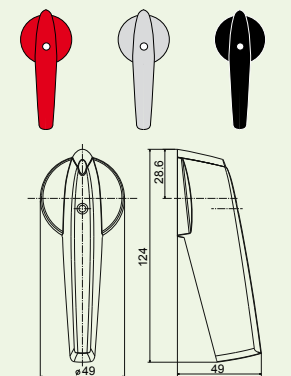

Lockable controller - medium



NVZ1R NVZ1S NVZ1C

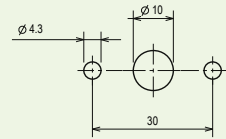
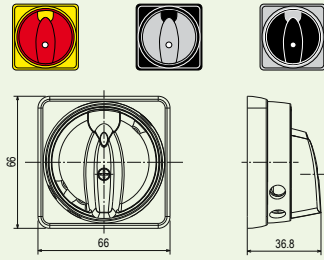

Lockable controller - medium



NVZ3R NVZ3S NVZ3C

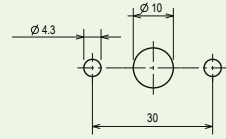
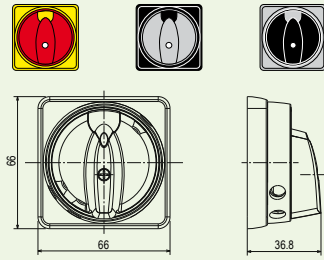

Lockable controller - large



NVZ2R NVZ2S NVZ2C

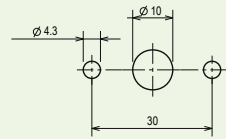
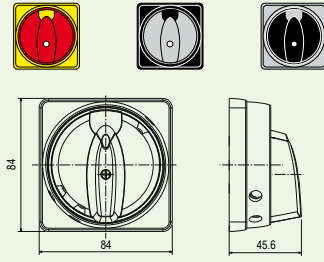

Lockable controller - medium



PNZ PNC

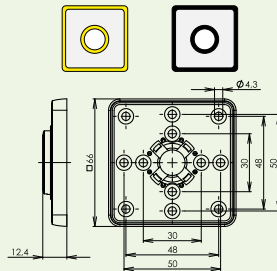

ZSR ZSS ZSC

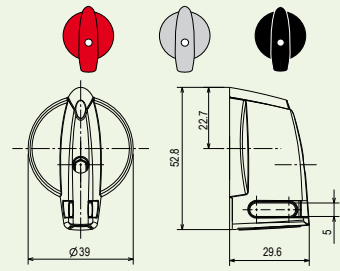

Allocation of controllers (for VSN 10 - 250, VSR 10 - 20 switches):

controller	VSN type									
	VSN 10 - 16 - 20		VSN 25 - 32		VSN 40 - 63 - 75		VSN 80 - 100 - 125 - 150		VSN 250	
number of switch levels	1-6	7-12	1-6	7-12	1-6	7-12	1-3	4-6	1-2	3-4
NM	✓	✗	✗	✗	✗	✗	✗	✗	✗	✗
NS/5	✓	✓	✗	✗	✗	✗	✗	✗	✗	✗
NS/6	✗	✗	✓	✗	✓	✗	✗	✗	✗	✗
ZS/5	✓	✓	✗	✗	✗	✗	✗	✗	✗	✗
ZS/6	✗	✗	✓	✗	✓	✗	✗	✗	✗	✗
NO	✗	✗	✓	✓	✓	✓	✓	✗	✓	✗
KS/5	✓	✓	✗	✗	✗	✗	✗	✗	✗	✗
KS/6	✗	✗	✓	✓	✓	✓	✓	✓	✓	✓
KO	✗	✗	✓	✓	✓	✓	✓	✓	✓	✓
NVZ1	✓	✓	✗	✗	✗	✗	✗	✗	✗	✗
NVZ2	✗	✗	✓	✓	✓	✓	✓	✓	✓	✗
NVZ3	✗	✗	✓	✗	✓	✗	✗	✗	✗	✗

Allocation of controllers to front panels (for VSN 10 - 250, VSR 10 - 20 switches):

front panel	controller		
	NM	NS	NO
AN	✓	✗	✗
PN	✗	✓	✗
PN/Z*	✗	✗	✗
HN	✗	✗	✓

front panel	controller		
	ZS	KS	KO
AN	✗	✗	✗
PN	✗	✓	✗
PN/Z*	✓	✗	✗
HN	✗	✗	✓

* as a spare part only

Note:
 NS/5, NS/6, ZS/5, ZS/6, KS/5 a KS/6 - final number 5, 6 indicates a shaft type - the number to be mentioned only when ordering a controller separately (not when ordering together with a switch).
 The table defines fitness of controllers to be used with the corresponding front panels up to the front panel thickness of 5 mm.

Front panel with a small additional plate

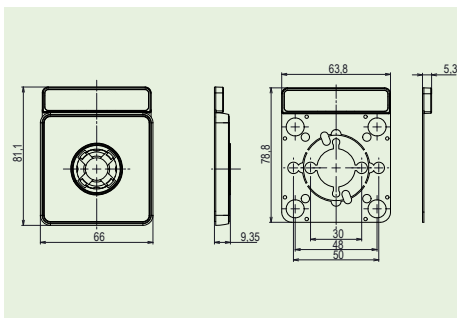

Front panels (PN) and locking equipment (NVZ1, NVZ3) of 66x66 mm can be supplemented with an additional front panel with a plate.

Additional front panels are black, plates are silver.

Specification:

PPNC1 (front panel with a small plate)

PPNC2 (front panel with a large plate)

Front panel with a large additional plate

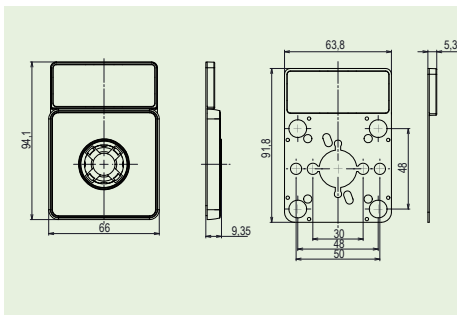

Model examples



Additional data plate for central front panel combined with the central mounting.



Additional data plate for central front panel combined with the central front panel.



Additional data plate for central front panel combined with the lockable extension.

Cam switch in the protection cover - alternatives



Cam switch in the protection cover with a fuse disconnecter - K2P type

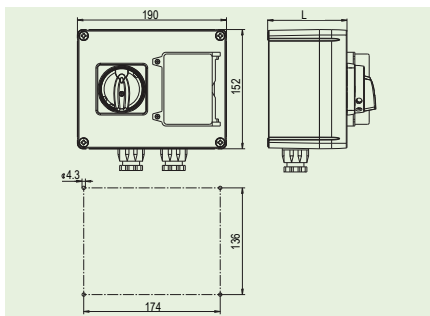

The cam switches VSN10 - 32 (VSR 10 - 20) with IP 65 in the protection cover are available with a fuse controller or a three-pole circuit breaker.

Cam switch in the protection cover with a socket - K2Z type

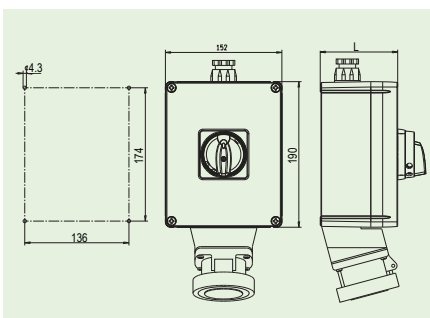

The cam switches VSN 16 - 32 with IP 65 in the protection cover are available with a socket (3P+PEN, 3P+PE+N).

Cam switch in a protection cover with inlet - type K2R

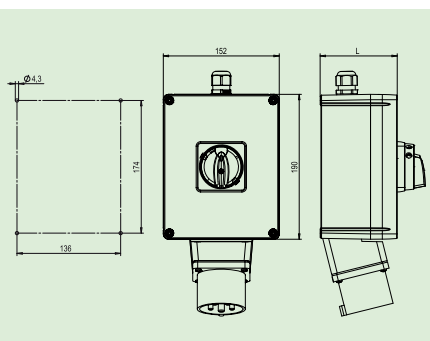

Available for cam switches VSN 16 - 32 with IP cover 54 and inlet (3P + PEN, 3P + PE + N).

VSR 10 - 16 - 20

VSN 10 - 16 - 20

VSN 25 - 32

VSN 40 - 63 - 75

VSN 80 - 100 - 125 - 150

VSN 250

HOW TO BUILD A SWITCH DESIGNATION

33

SWITCHES, CHANGE-OVER SWITCHES

34

RESISTOR CHANGE SWITCHES

51

MEASURING DEVICE SWITCHES

52

ONE-PHASE MOTOR SWITCHES

56

THREE-PHASE ASYNCHRONOUS MOTOR SWITCHES

57

**SPECIFICATION OF A TAILOR-MADE SWITCHING PROGRAM
BY A CUSTOMER**

61

EXAMPLE OF FORMING A TYPE NUMBER

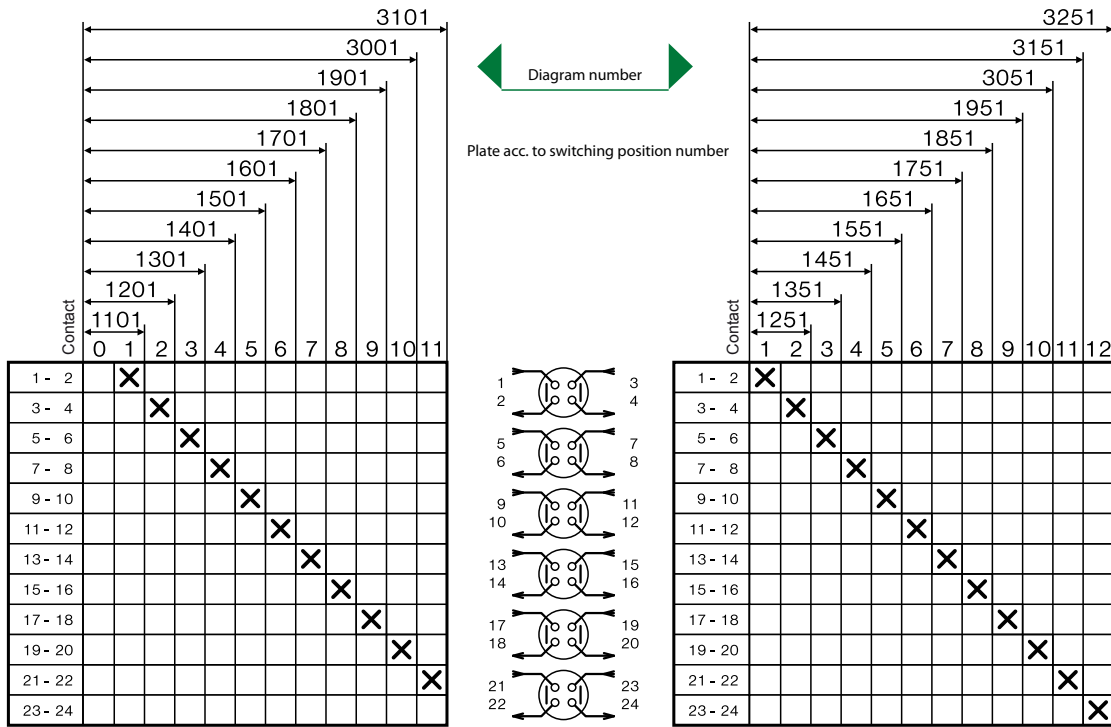

EXAMPLES OF SWITCHING PROGRAM MULTIPLICITY AND SPECIFICATION TYPE

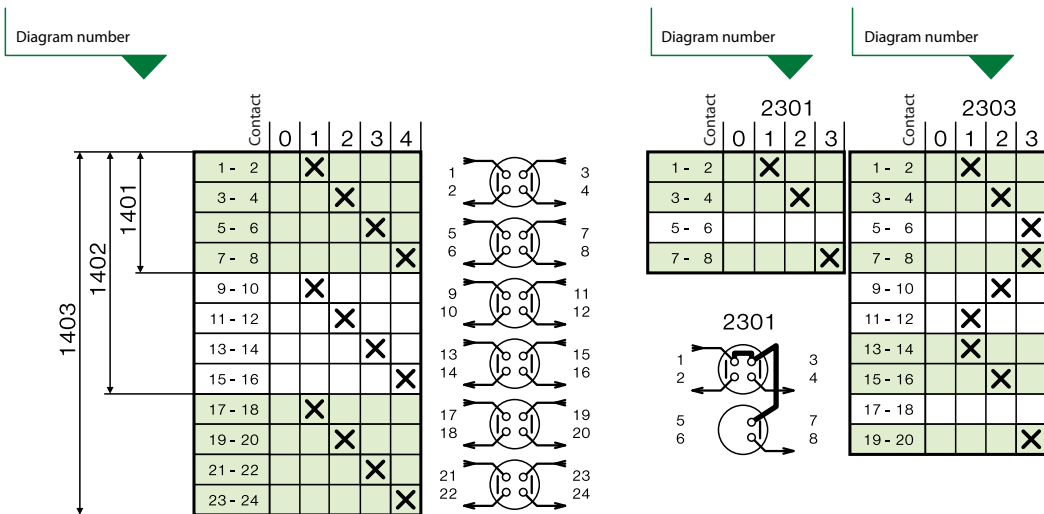

Diagram number

Identification on plate

		Contact		
		0	1	
1	3	X		1101
2	4	X		1102
5	7	X		1103
6	8	X		1104
9	11	X		1105
10	12	X		1106
13	15	X		1107
14	16	X		1108
17	19	X		1109
18	20	X		1110
21	23	X		1111
22	24	X		1112
25	27	X		1113
26	28	X		1114
29	31	X		1115
30	32	X		1116
33	35	X		1117
34	36	X		1118
37	39	X		1119
38	40	X		1120
41	43	X		1121
42	44	X		1122
45	47	X		1123
46	48	X		1124

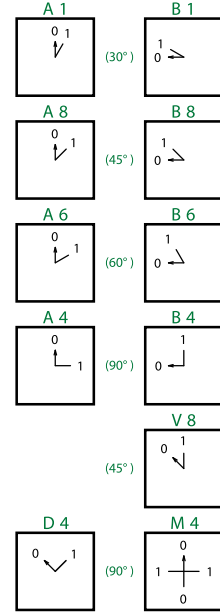

Diagram number

Identification on plate

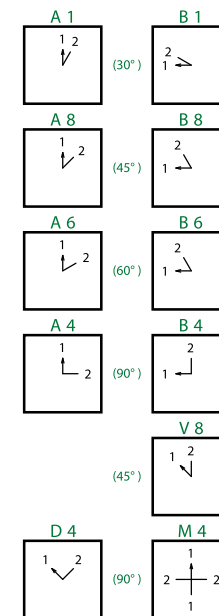
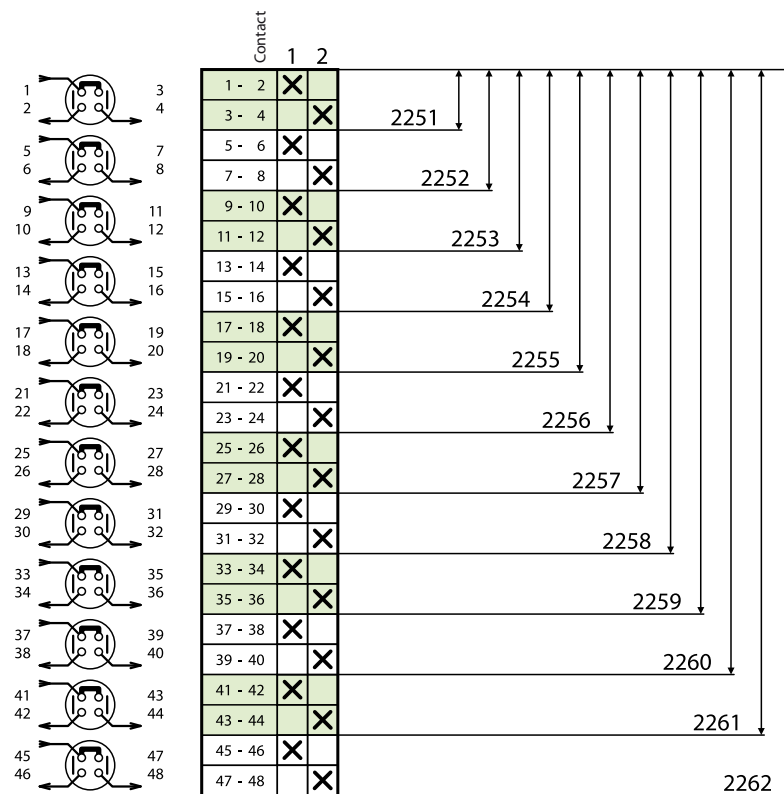
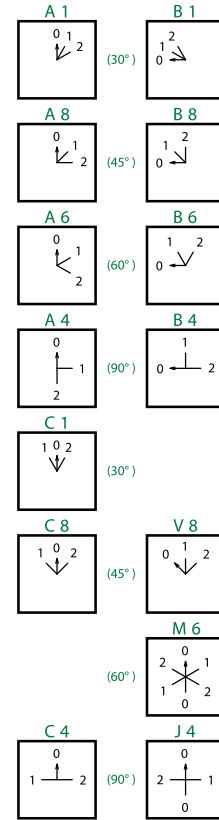
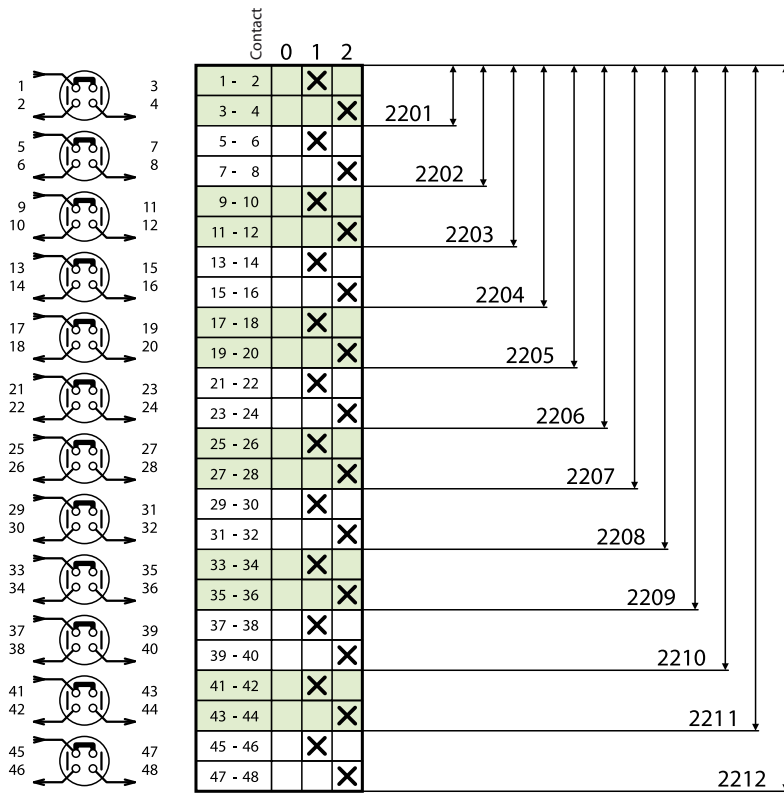
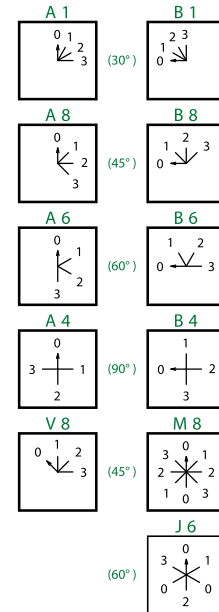
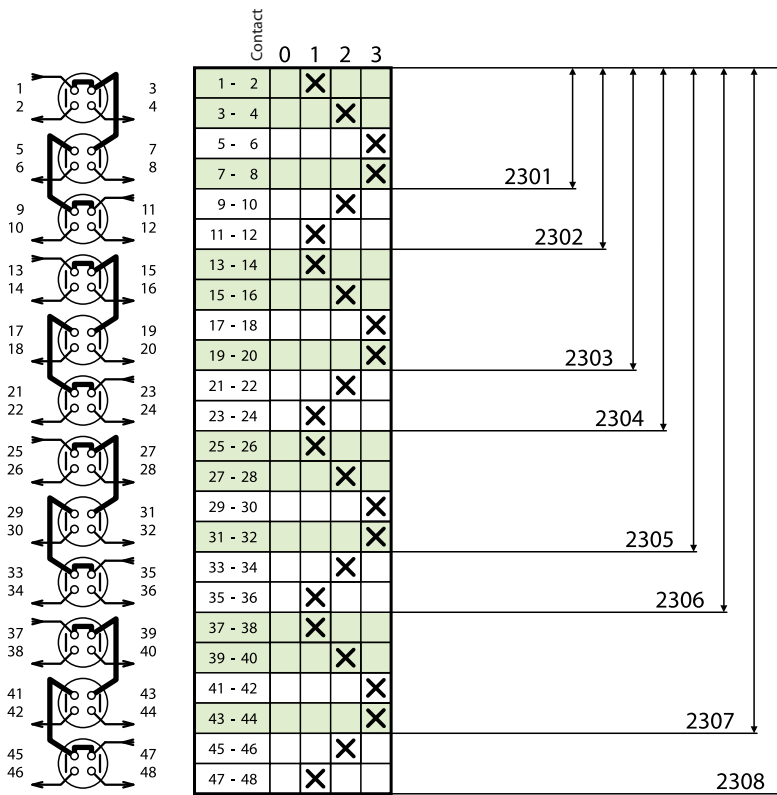
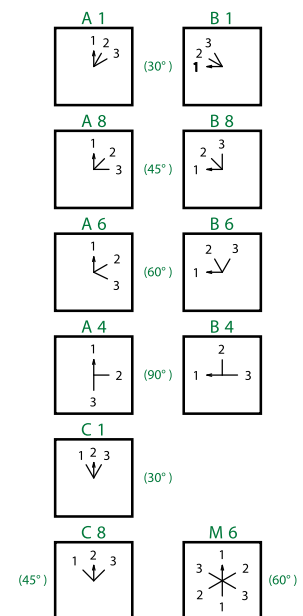
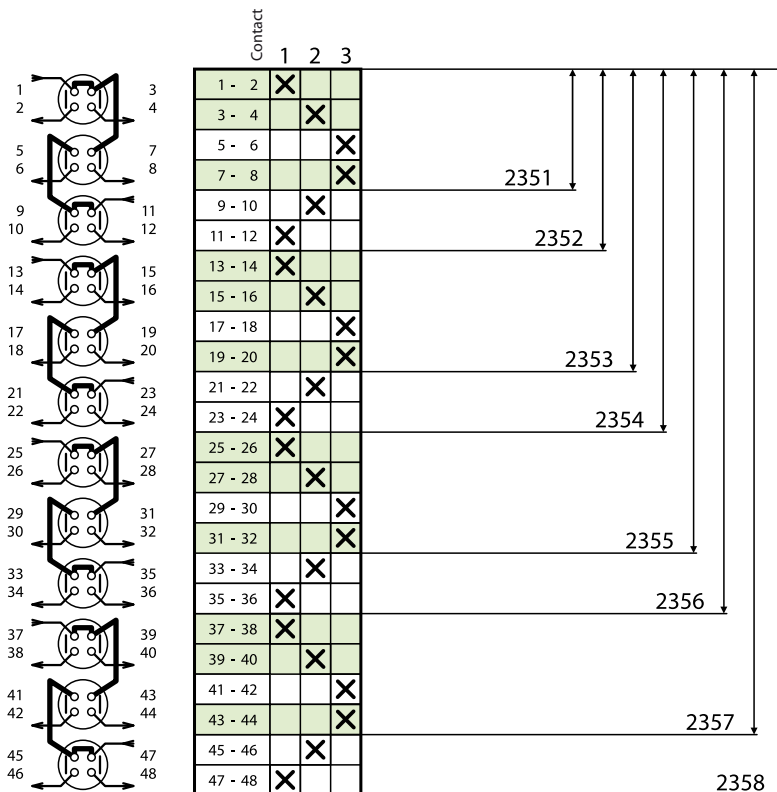

Diagram number

Identification on plate



Warning	
Diagram number	Idle contact
2301	5 - 6
2303	17 - 18
2305	29 - 30
2307	41 - 42



Warning	
Diagram number	Idle contact
2351	5 - 6
2353	17 - 18
2355	29 - 30
2357	41 - 42

Diagram number

Identification on plate

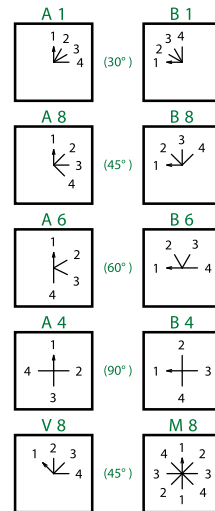
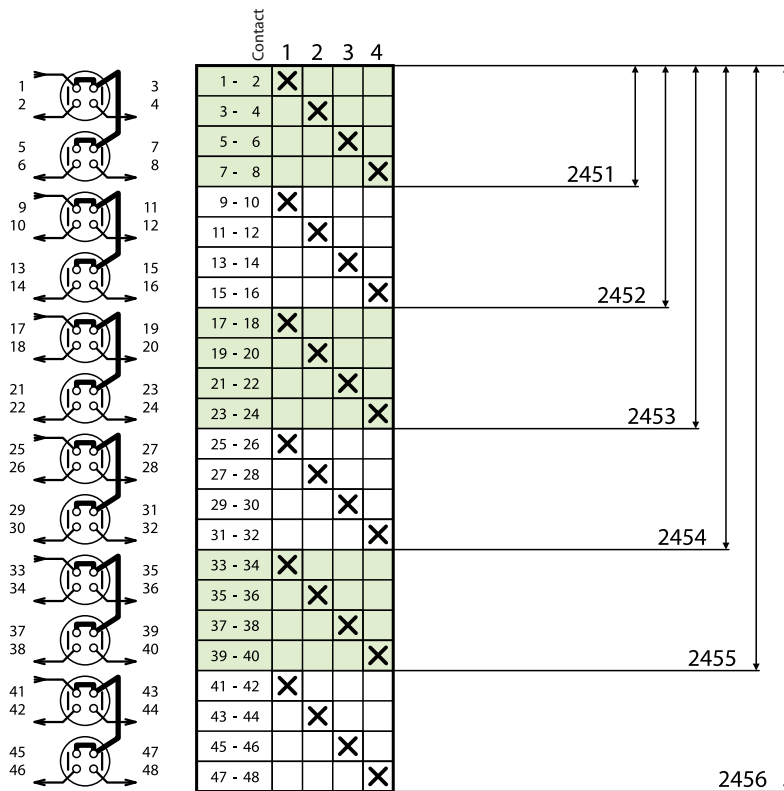
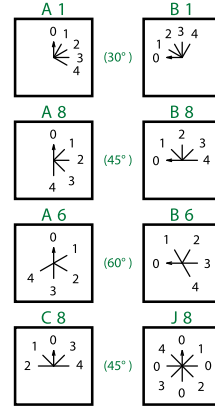
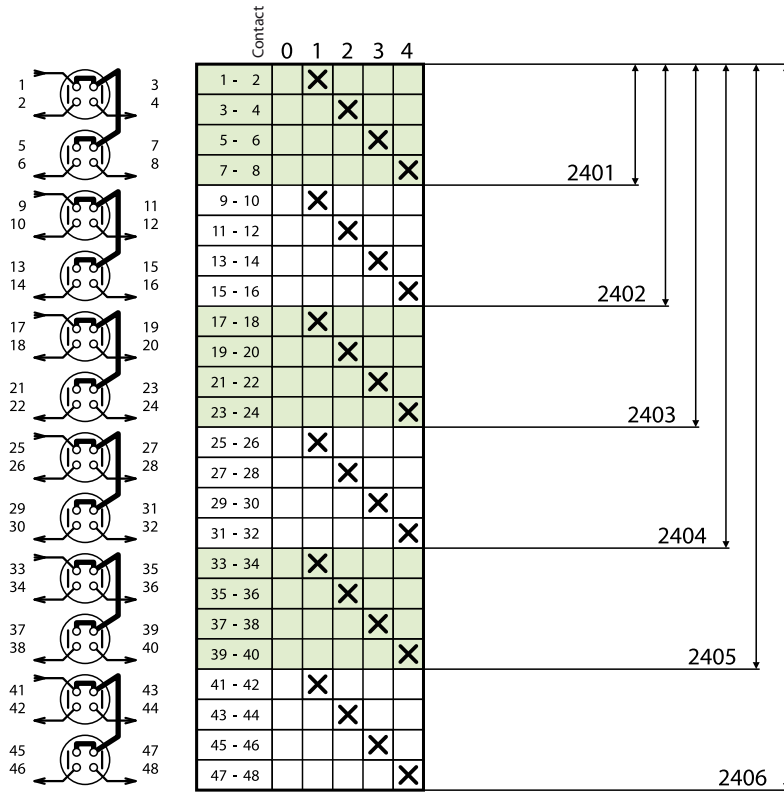

Diagram number

Identification on plate

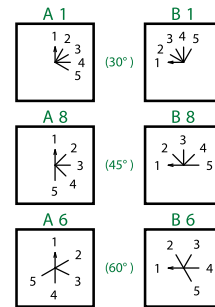
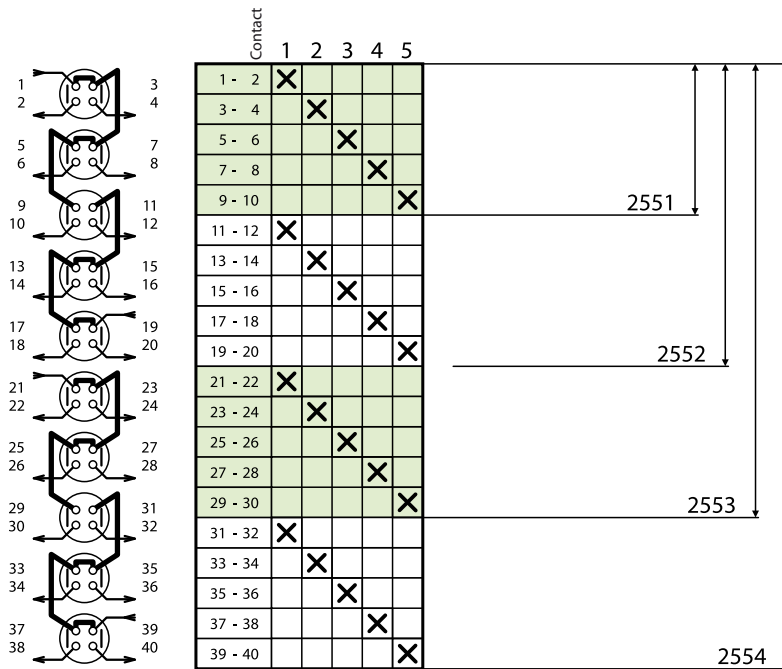
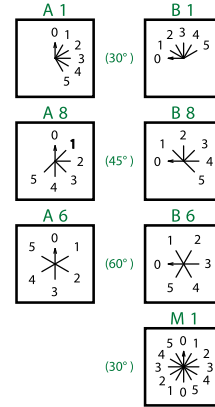
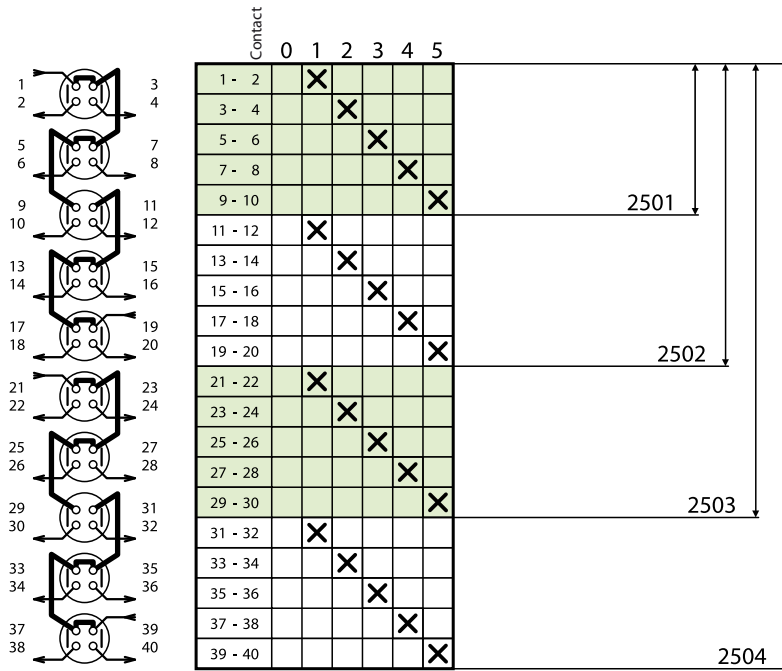

Diagram number

Identification on plate

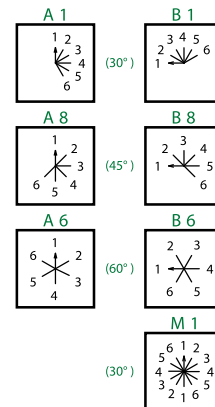
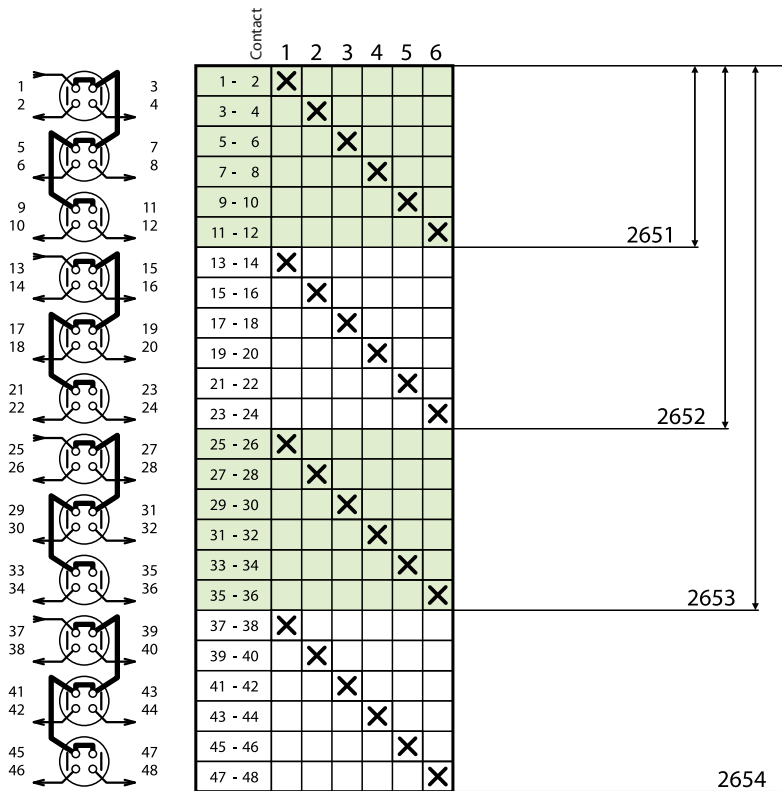
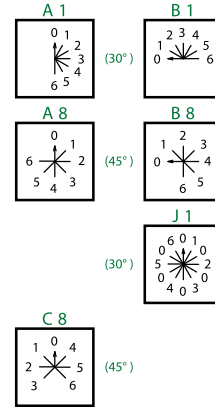
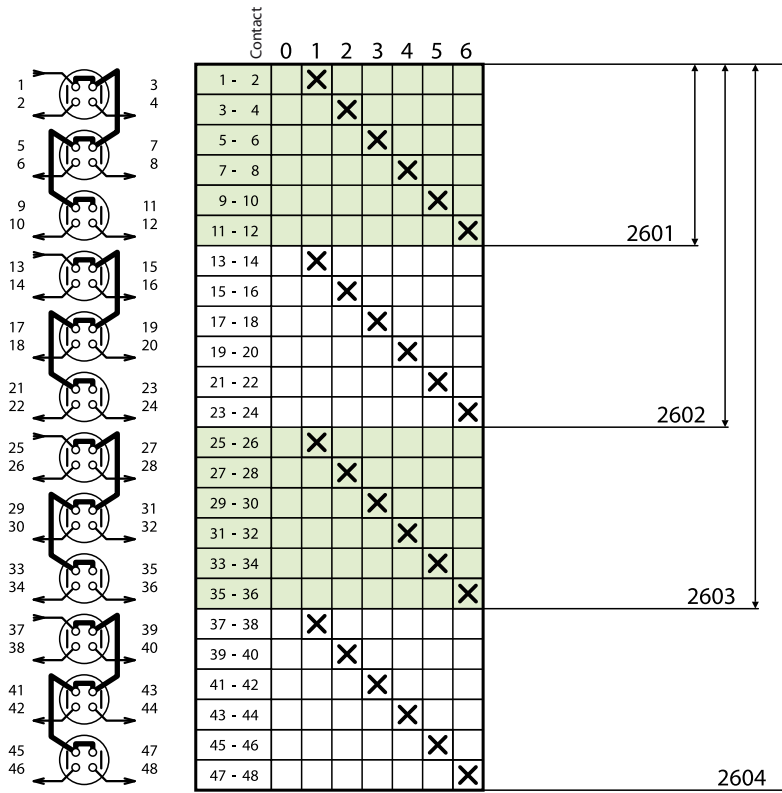
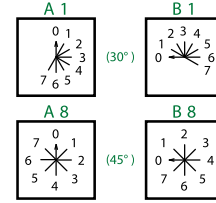
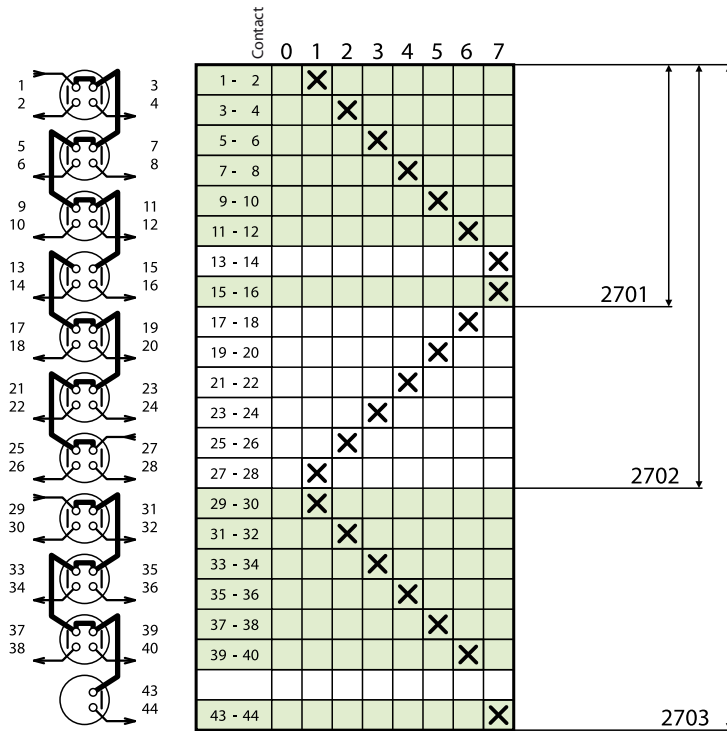
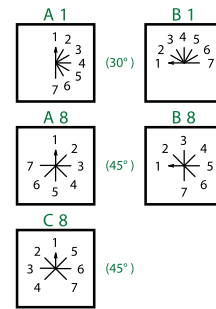
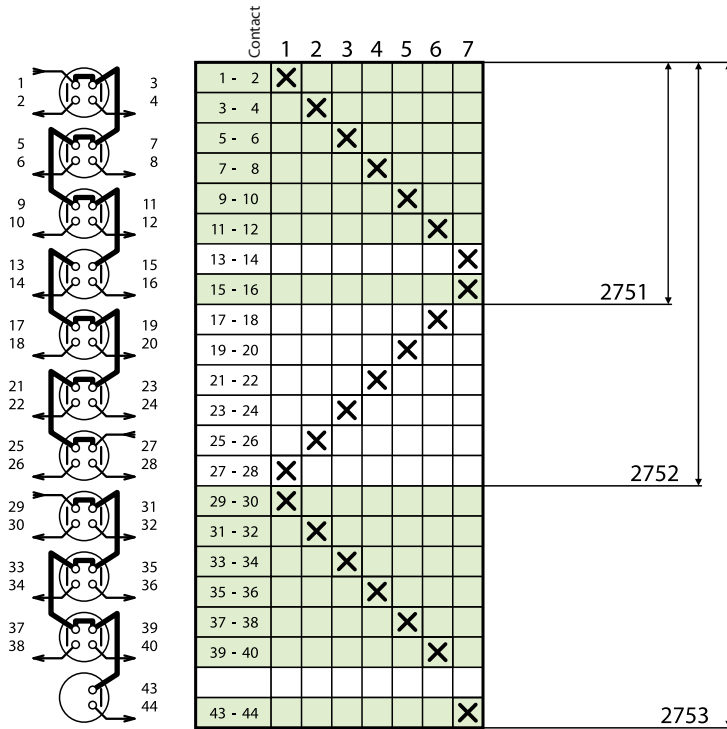

Diagram number

Identification on plate



Warning	
Diagram number	Idle contact
2701	13 - 14
2703	41 - 42



Warning	
Diagram number	Idle contact
2751	13 - 14
2753	41 - 42

Diagram number

Identification on plate

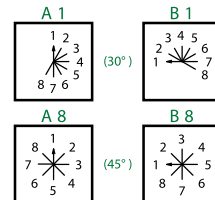
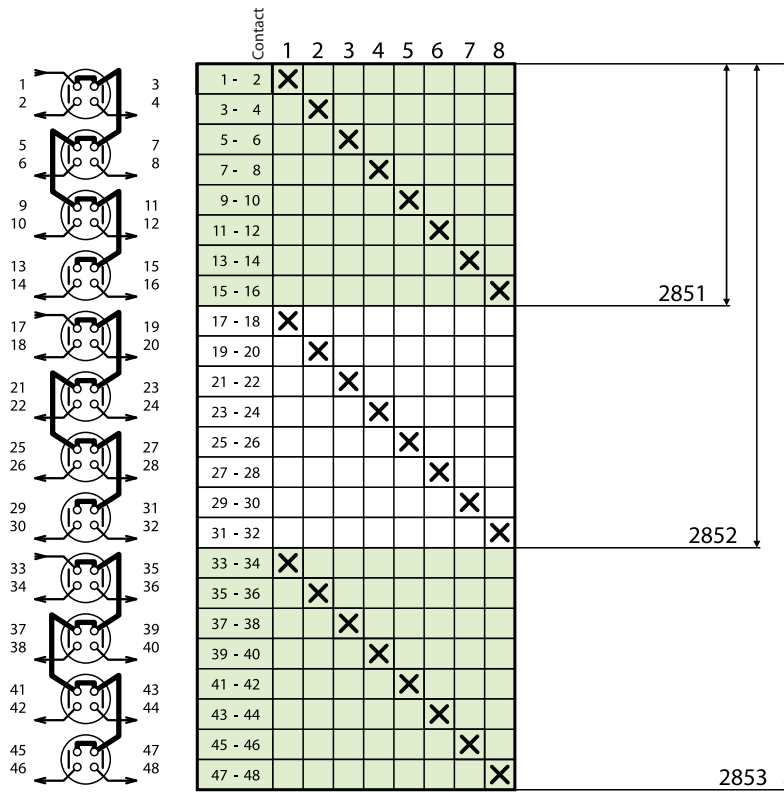
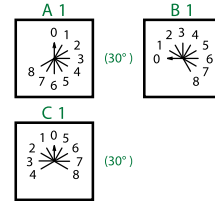
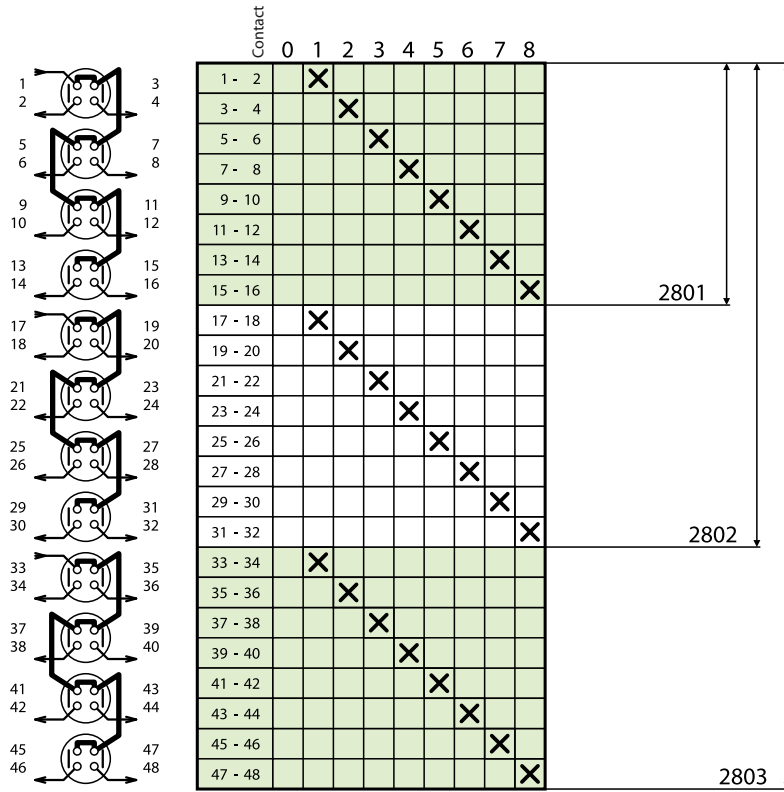

Diagram number

Identification on plate

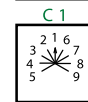
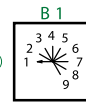
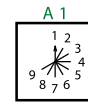
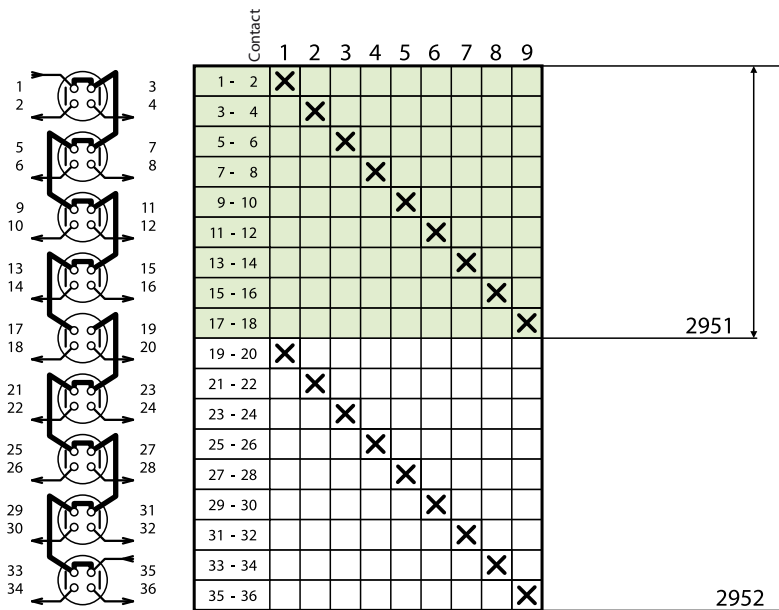
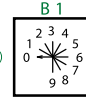
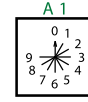
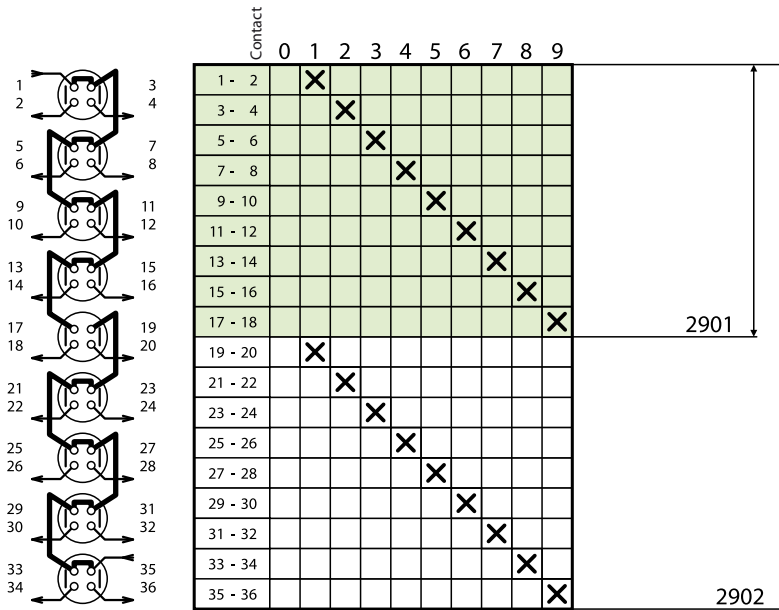

Diagram number

Identification on plate

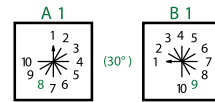
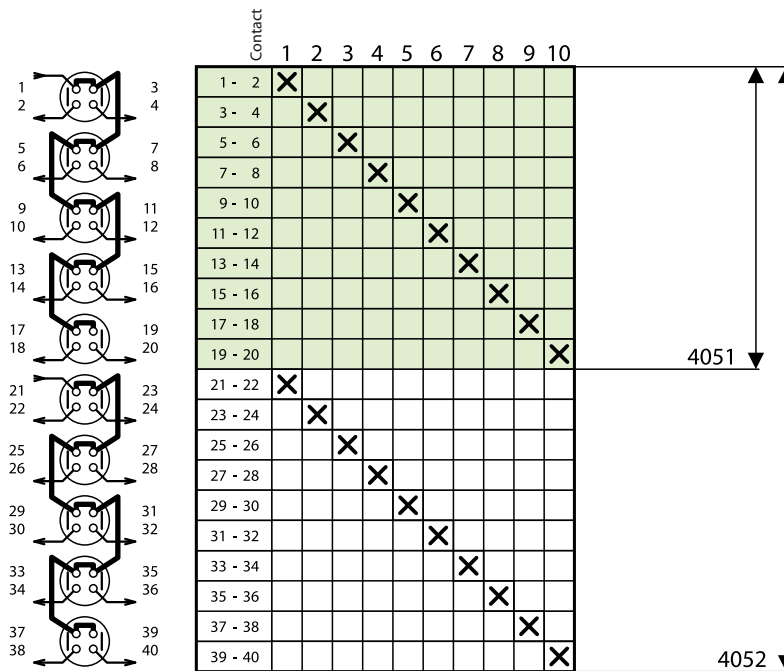
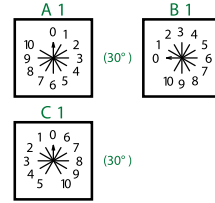
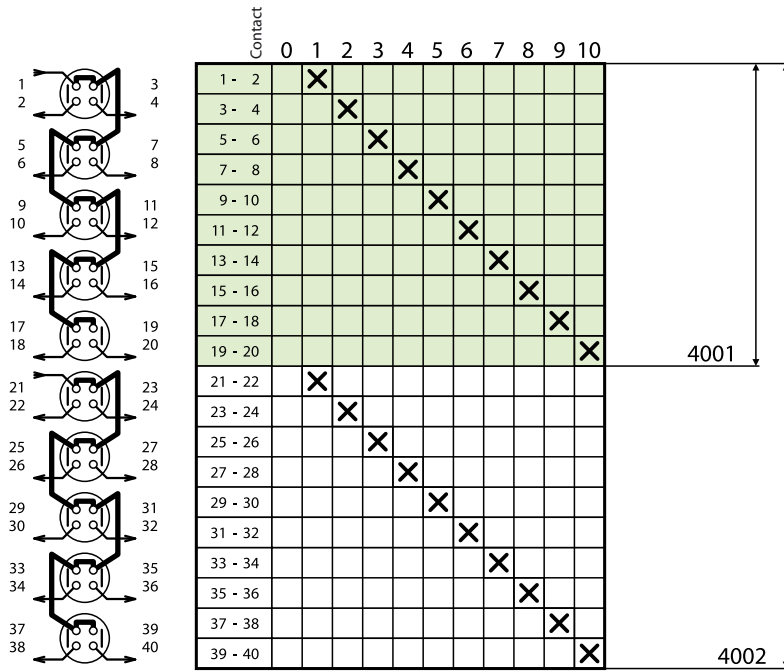
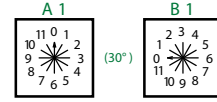
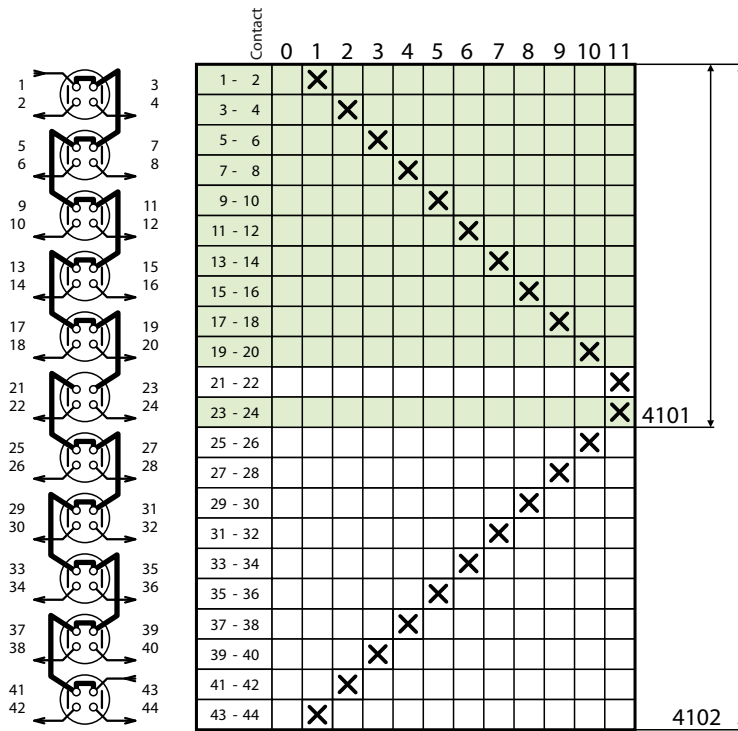
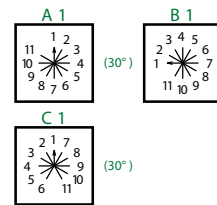
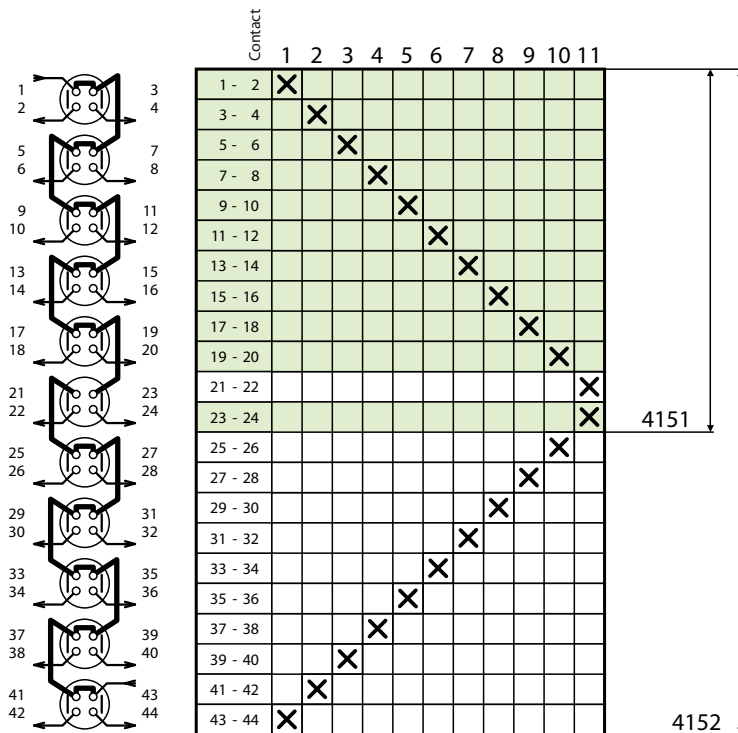

Diagram number

Identification on plate



Warning	
Diagram number	Idle contact
4101	21 - 22



Warning	
Diagram number	Idle contact
4151	21 - 22

Diagram number

Identification on plate

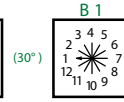
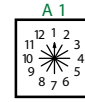
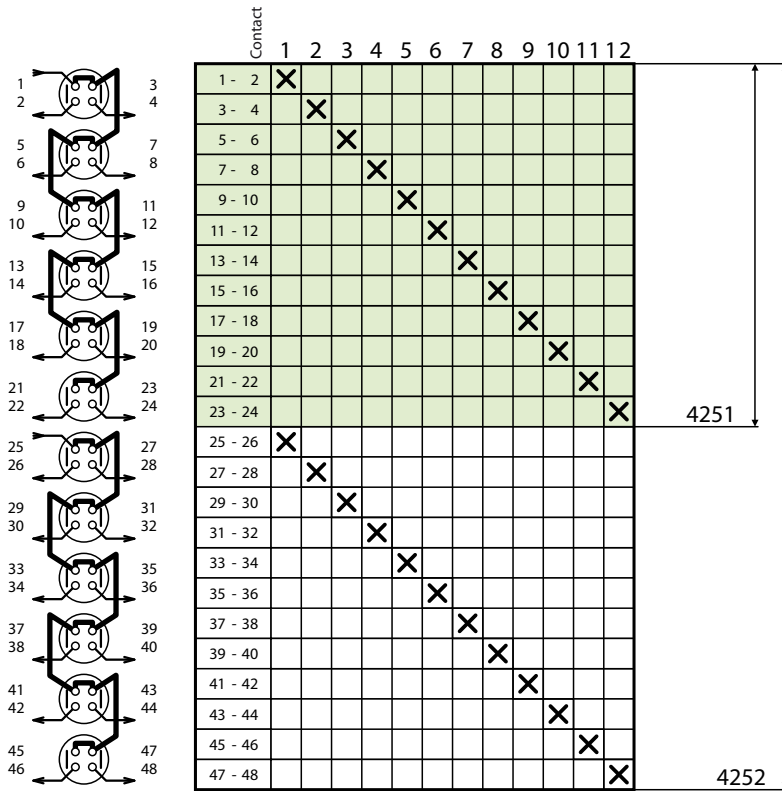
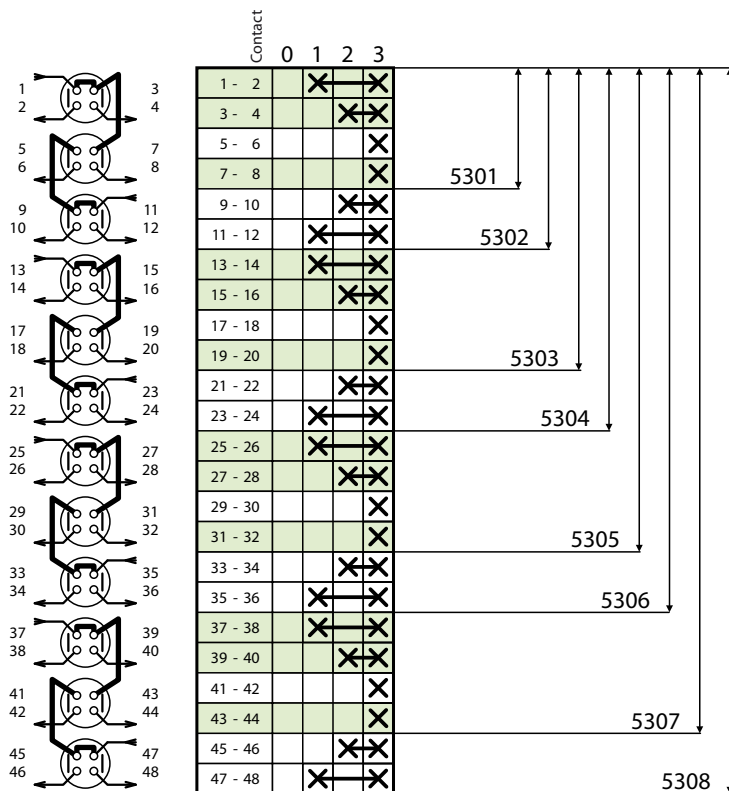
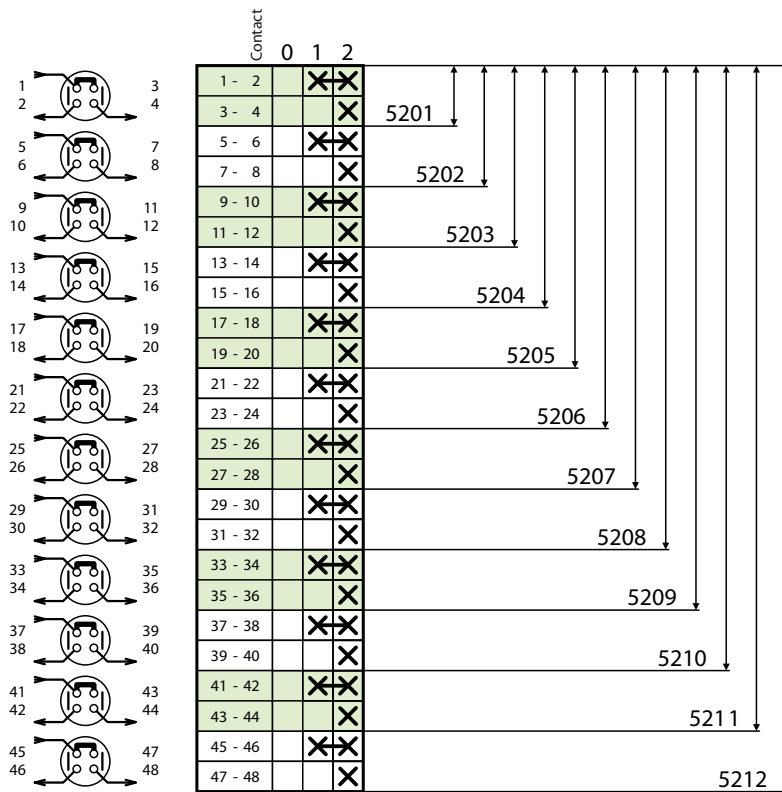

Diagram number

Identification on plate



Warning	
Diagram number	Idle contact
5301	5 - 6
5303	17 - 18
5305	29 - 30
5307	41 - 42

Diagram number

Identification on plate

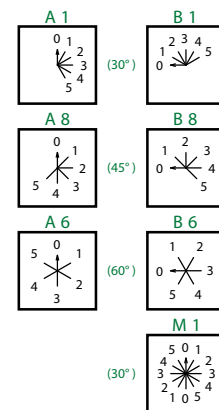
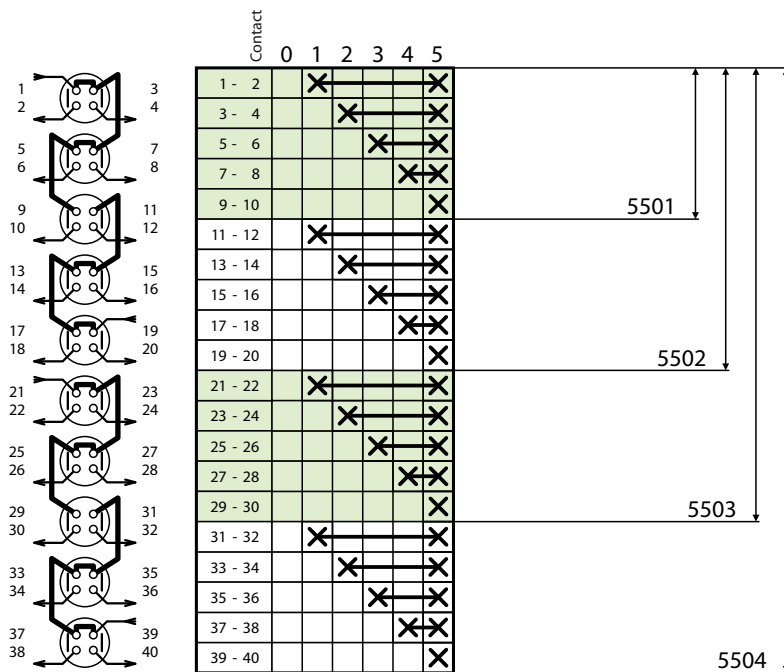
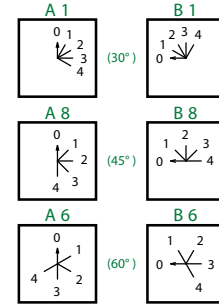
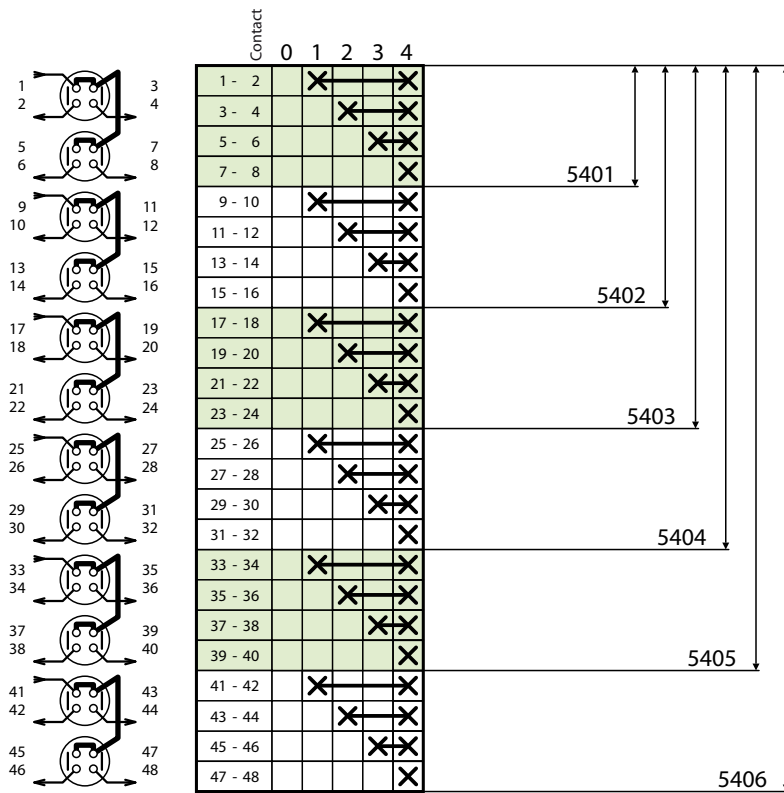
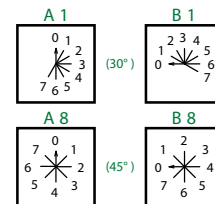
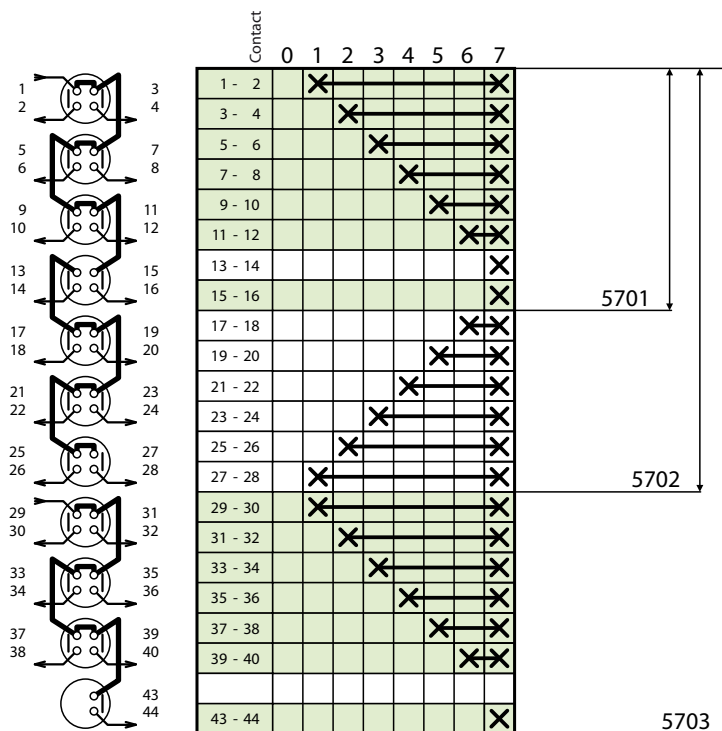
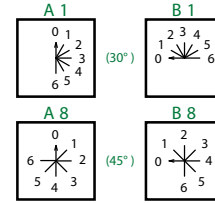
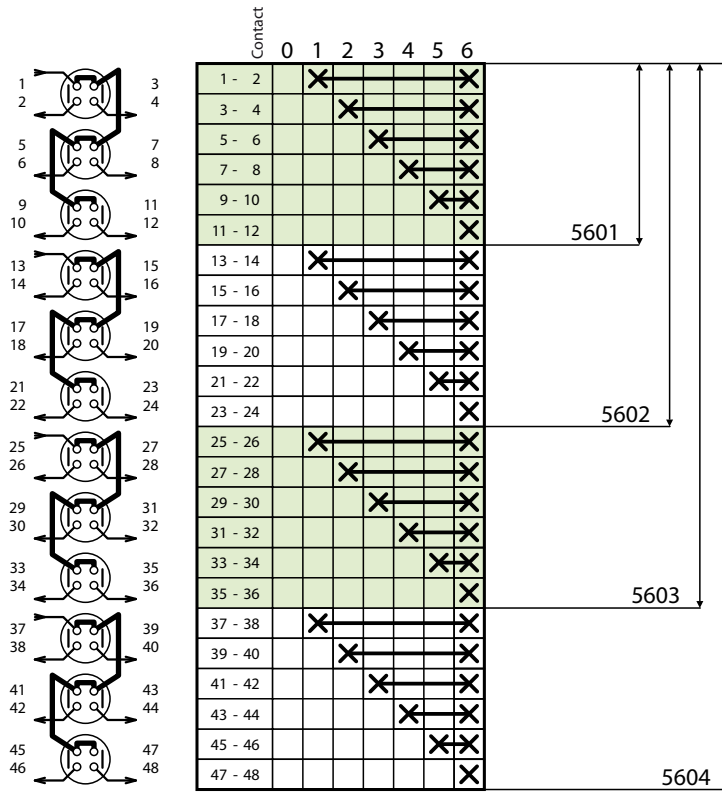

Diagram number

Identification on plate



Warning	
Diagram number	Idle contact
5701	13 - 14
5703	41 - 42

Diagram number

Identification on plate

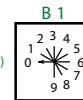
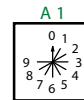
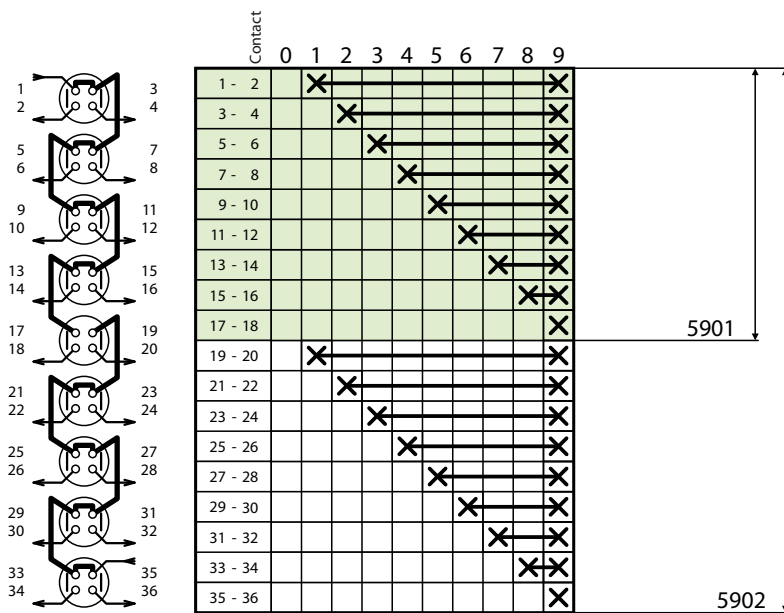
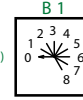
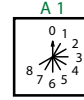
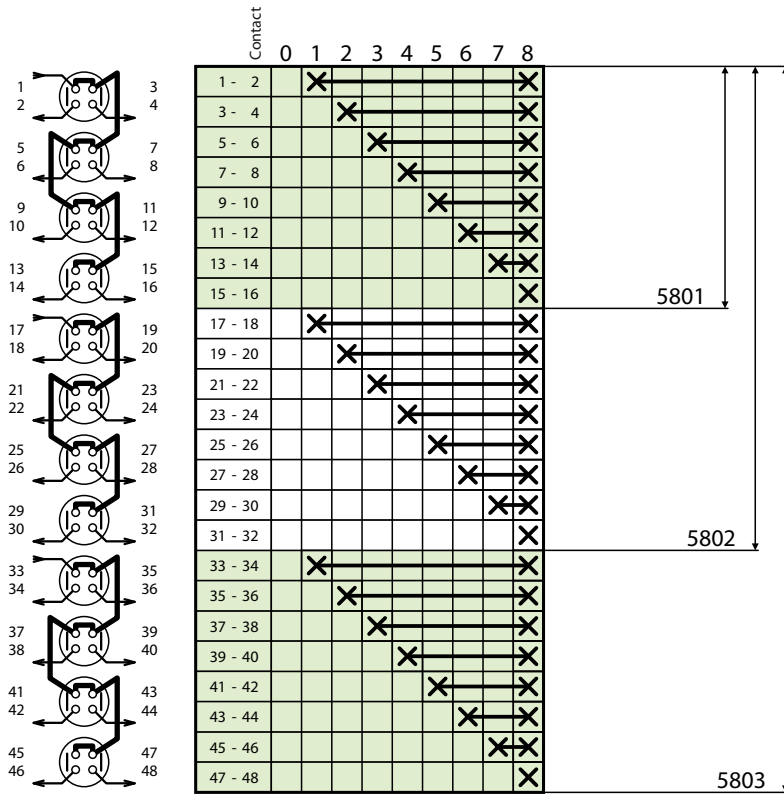
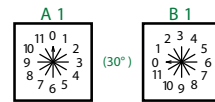
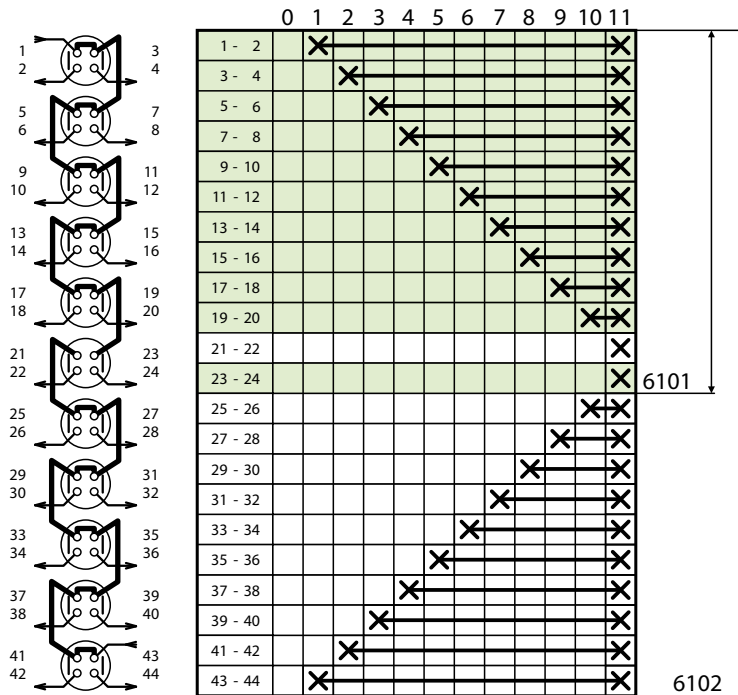
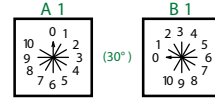
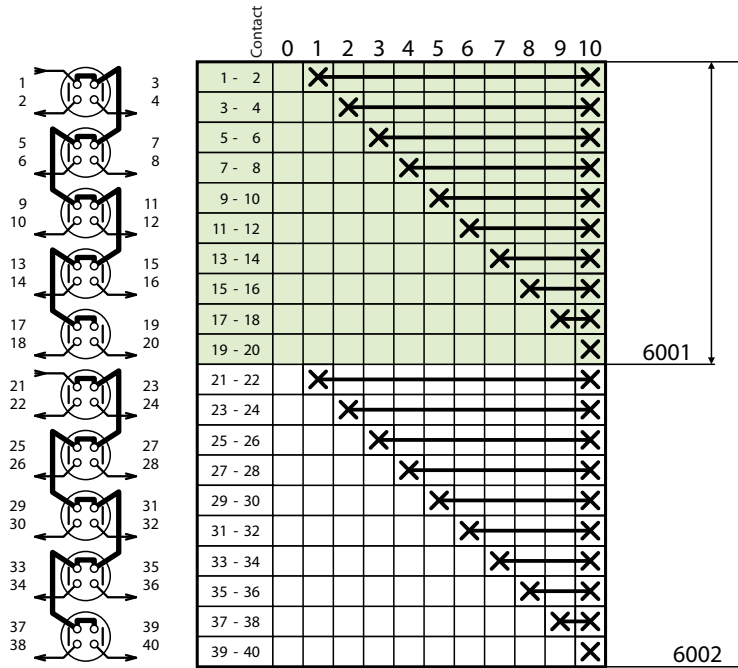

Diagram number

Identification on plate



Warning	
Diagram number	Idle contact
6101	21 - 22

Diagram number

Identification on plate

7202

Contact	0	1	2	3
1 - 2		X	X	
3 - 4				X
5 - 6			X	X
7 - 8	X			

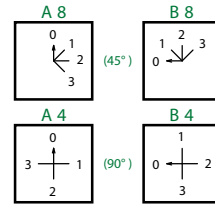
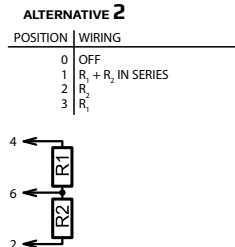
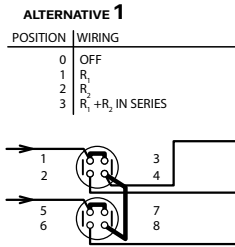

7204

Contact	0	1	2	3
1 - 2		X	X	X
3 - 4				X
5 - 6			X	X
7 - 8	X			

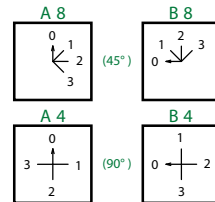
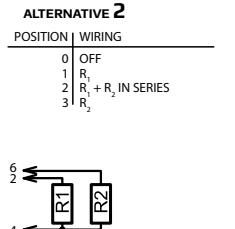
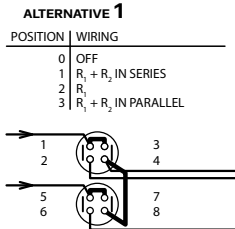

7207

Contact	0	1	2	3
1 - 2		X		X
3 - 4			X	X
5 - 6		X		X
7 - 8			X	X

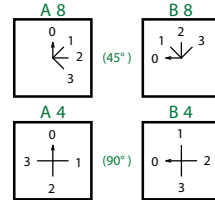
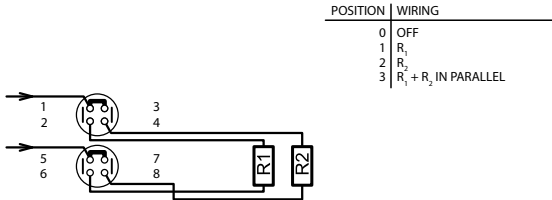

7211

Contact	0	1	2	3
1 - 2		X	X	X
3 - 4			X	X
5 - 6			X	X
7 - 8	X	X	X	X
9 - 10			X	X
11 - 12				X

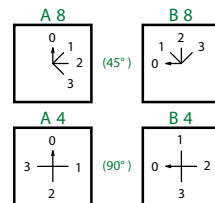
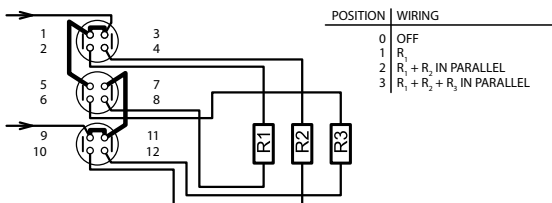

7607

Contact	0	1	2	3
1 - 2		X	X	X
3 - 4			X	X
5 - 6		X	X	X
7 - 8			X	X

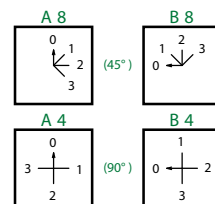
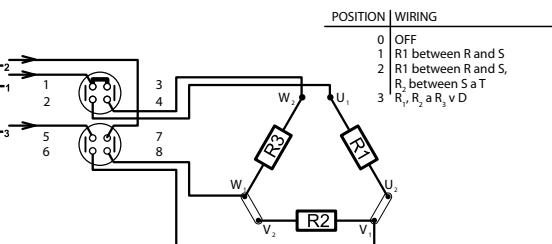
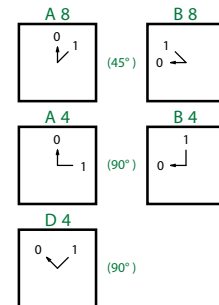
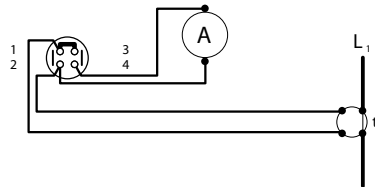
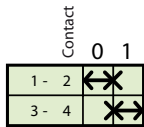

Diagram number

Identification on plate

8051



8052

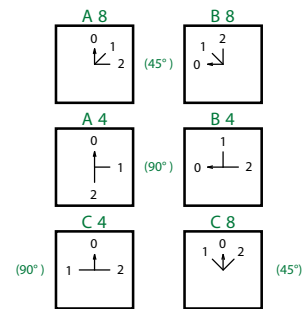
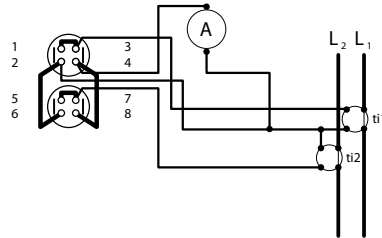
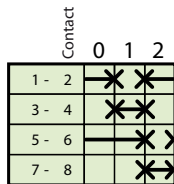

8053

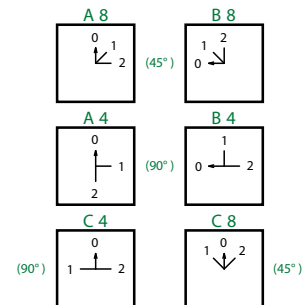
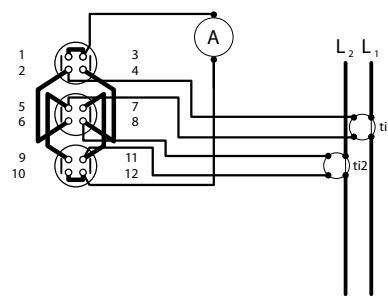
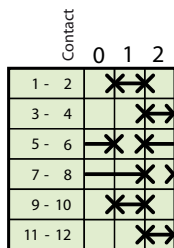

8101

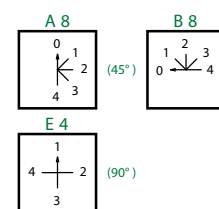
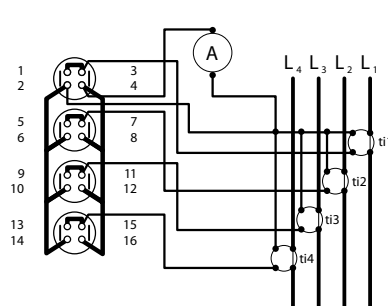
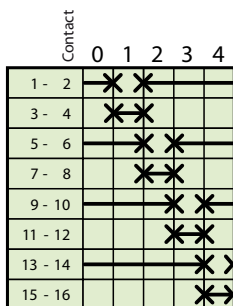
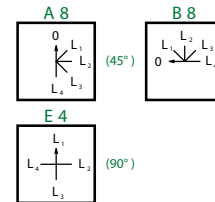
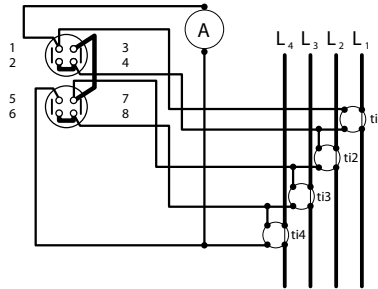
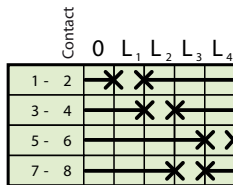

Diagram number

Identification on plate

8102



8151

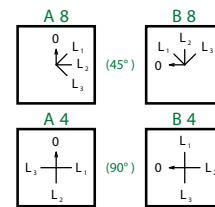
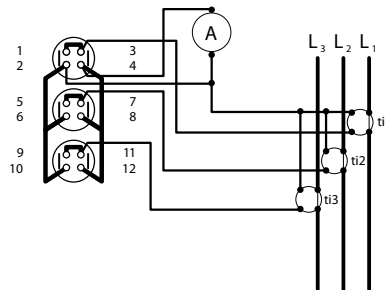
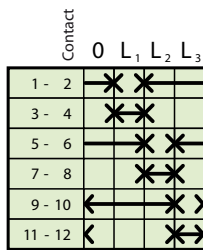

8157

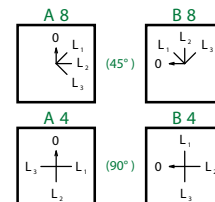
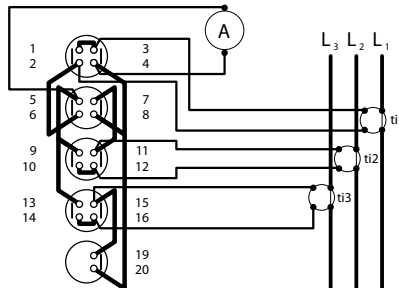
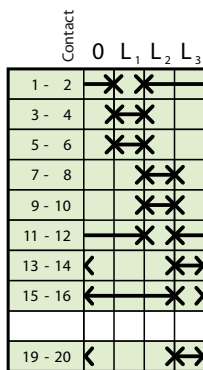

8164

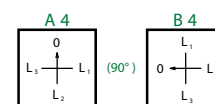
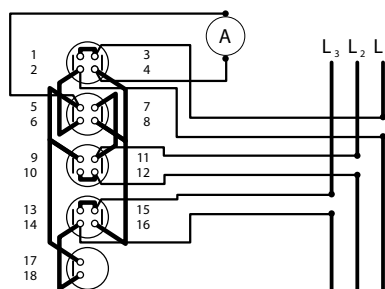
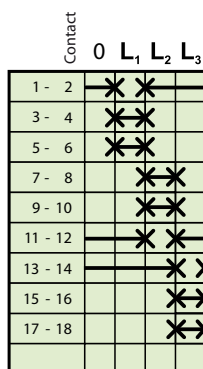
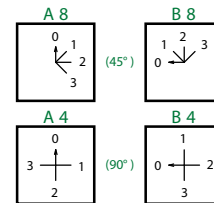
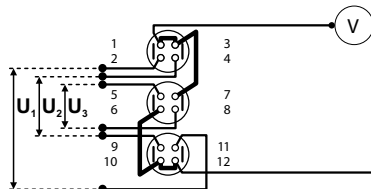

Diagram number

Identification on plate

8256

Contact	0	1	2	3
1 - 2		X		
3 - 4			X	
5 - 6				X
7 - 8				X
9 - 10		X		
11 - 12	X			



8351

Contact	0	L ₁ L ₂	L ₂ L ₃	L ₁ L ₃
1 - 2		X		X
3 - 4			X	
5 - 6		X	X	
7 - 8				X

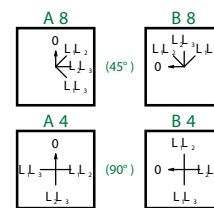
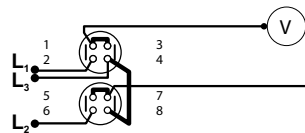

8357

Contact	L ₁ L ₃	L ₂ L ₃	L ₁ L ₂	0	L ₁ N	L ₂ N	L ₃ N
1 - 2	X		X		X		
3 - 4					X	X	X
5 - 6		X				X	
7 - 8			X				
9 - 10							X
11 - 12	X	X					

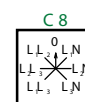
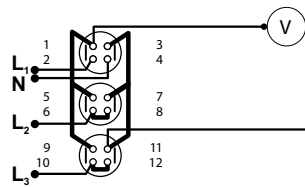

8359

Contact	L ₁ L ₃	L ₂ L ₃	L ₁ L ₂	0	L ₁ 2L ₂	L ₂ 2L ₃	L ₁ L ₃
1 - 2	X		X				
3 - 4					X		X
5 - 6		X					
7 - 8						X	
9 - 10			X				
11 - 12					X		
13 - 14	X	X					
15 - 16						X	X

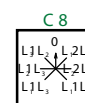
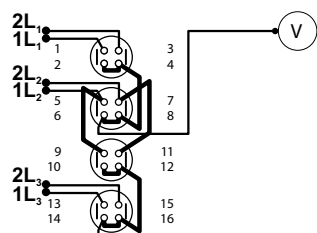
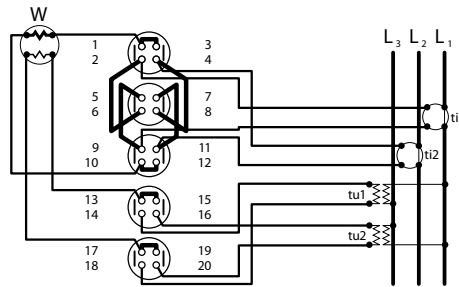

Diagram number

8453

		Contact		
		L ₁ L ₃	0	L ₂ L ₃
1 - 2		*	*	
3 - 4		*	*	*
5 - 6		*	*	*
7 - 8		*	*	*
9 - 10		*	*	*
11 - 12		*	*	*
13 - 14		*		*
15 - 16		*		*
17 - 18		*		*
19 - 20		*		*



Identification on plate

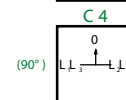
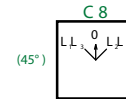

8551

		Contact		
		0	N ₁ N ₂	N ₂ N ₃
1 - 2		*	*	*
3 - 4		*	*	*
5 - 6		*	*	*
7 - 8		*	*	*
9 - 10		*	*	*
11 - 12		*	*	*
13 - 14		*	*	*
15 - 16		*	*	*
17 - 18		*	*	*

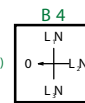
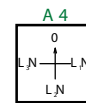
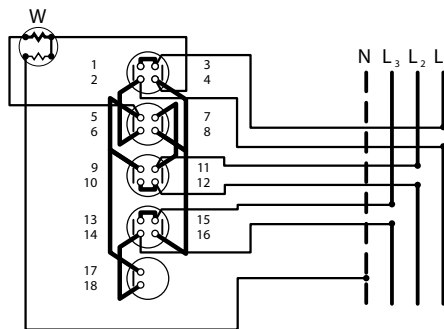

8752

		Contact		
		0	L ₁ L ₂	L ₂ L ₃
1 - 2		*	*	*
3 - 4		*	*	*
5 - 6		*	*	*
7 - 8		*	*	*
9 - 10		*	*	*
11 - 12		*	*	*
13 - 14		*	*	*
15 - 16		*	*	*
17 - 18		*	*	*
19 - 20		*	*	*

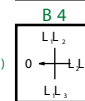
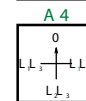
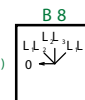
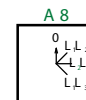
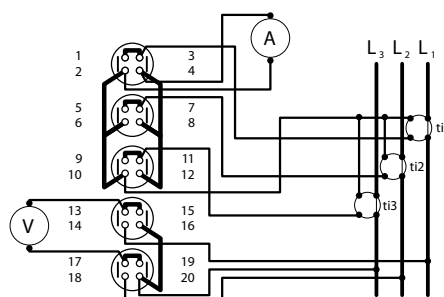
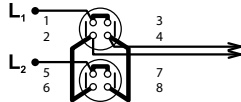

Diagram number

9051

		Contact		
		0	1	2
1 - 2			X	
3 - 4				X
5 - 6				X
7 - 8		X		



Identification on plate

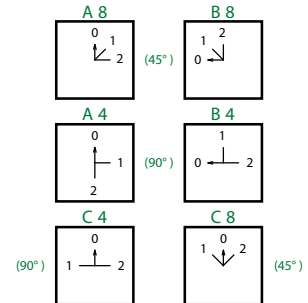

9101

		Contact		
		1	0	2
1 - 2	X			X
3 - 4	X			X
5 - 6				X
7 - 8	X			
9 - 10	X			
11 - 12				X

Reverse change-over switch

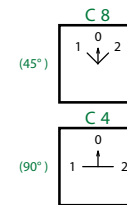
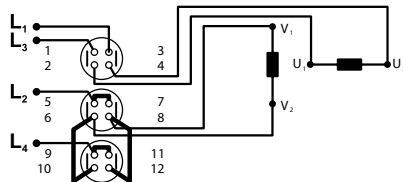

9256

		Contact	
		1	2
1 - 2	X	X	
3 - 4			X
5 - 6			X
7 - 8	X		
9 - 10	X	X	

POLOHA | CONNECTION

- 1 In-series winding (220 V)
- 2 In-parallel winding (110 V)

- 1 In-series winding (220 V)
- 2 In-parallel winding (110 V)

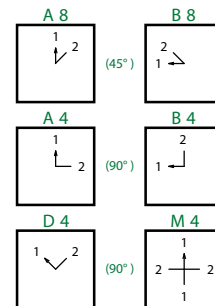
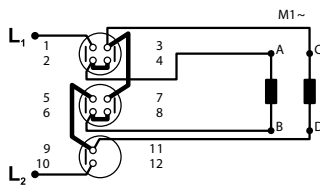

9455

		Contact		
		0	1	2
1 - 2		X	X	
3 - 4		X	X	
5 - 6		X	X	

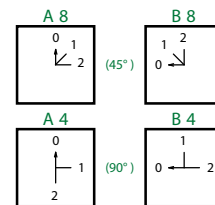
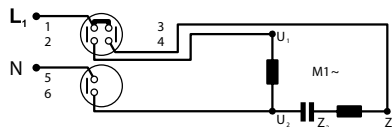

9501

		Contact		
		0	1	2
1 - 2			X	
3 - 4		X		
5 - 6			X	
7 - 8		X		
9 - 10		X	X	
11 - 12		X	X	

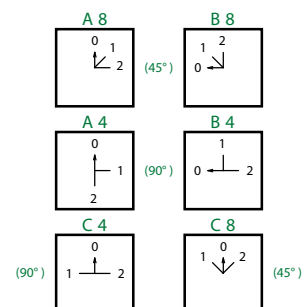
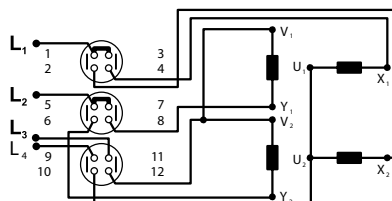
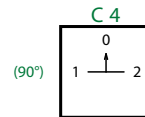
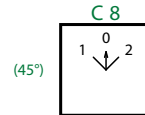
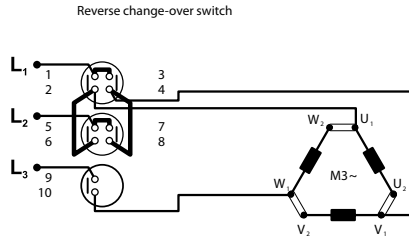

Diagram number

Identification on plate

9151

Contact	1	0	2
1 - 2	✗		
3 - 4			✗
5 - 6			✗
7 - 8	✗		
9 - 10	✗		✗



9153

Contact	Δ	Y	0	Y	Δ
1 - 2				✗	✗
3 - 4	✗	✗			
5 - 6	✗	✗			
7 - 8				✗	✗
9 - 10	✗				✗
11 - 12	✗				✗
13 - 14		✗		✗	
15 - 16		✗		✗	
17 - 18	✗				✗
19 - 20	✗	✗		✗	✗

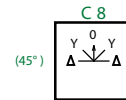
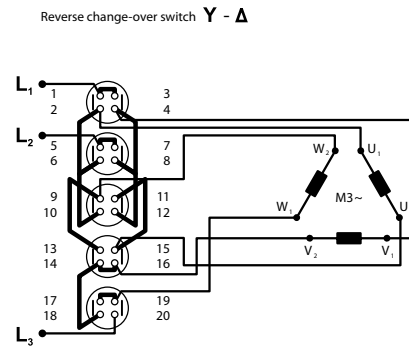

9352

Contact	Y	Δ
1 - 2	✗	
3 - 4		✗
5 - 6	✗	
7 - 8		✗
9 - 10		✗

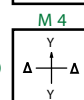
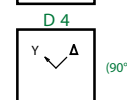
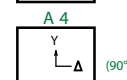
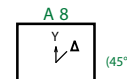
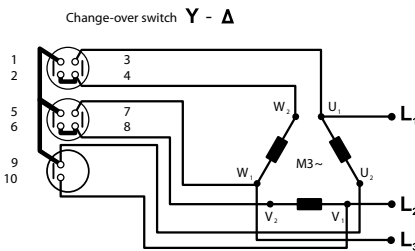

9551

Contact	0	Y	Δ
1 - 2		✗	✗
3 - 4			✗
5 - 6			✗
7 - 8	✗		
9 - 10		✗	✗
11 - 12		✗	
13 - 14		✗	✗
15 - 16			✗

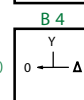
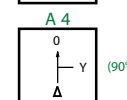
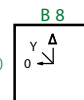
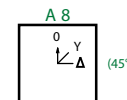
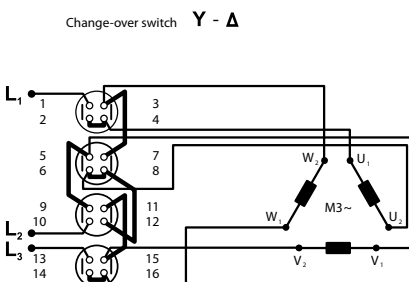

Diagram number

Identification on plate

9154

Contact	2	1	0	1	2
1 - 2				X	X
3 - 4	X	X			
5 - 6	X	X			
7 - 8				X	X
9 - 10	X				X
11 - 12	X				X
13 - 14		X		X	
15 - 16		X		X	
17 - 18	X				X
19 - 20	X				X
21 - 22	X				X
23 - 24	X			X	

Pole reverse change-over switch (DAHLANDER)

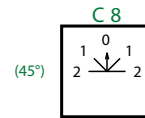
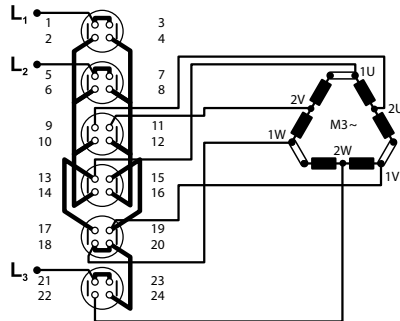

9354

	1	2
1 - 2	X	
3 - 4		X
5 - 6		X
7 - 8	X	
9 - 10		X
11 - 12		X
13 - 14	X	
15 - 16		X

Pole change-over switch $\Delta - \Upsilon$ (DAHLANDER)

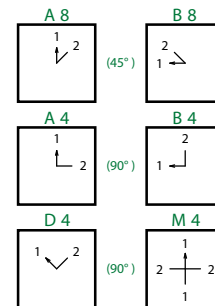
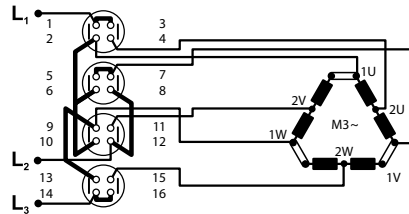

9552

Contact	0	1	2
1 - 2		X	
3 - 4			X
5 - 6			X
7 - 8		X	
9 - 10			X
11 - 12			X
13 - 14		X	
15 - 16			X

Pole change-over switch $\Delta - \Upsilon$ (DAHLANDER)

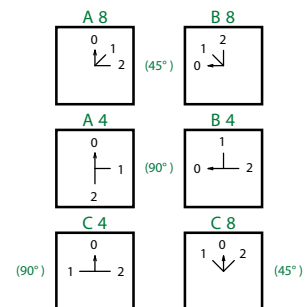
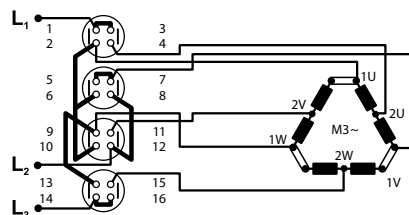
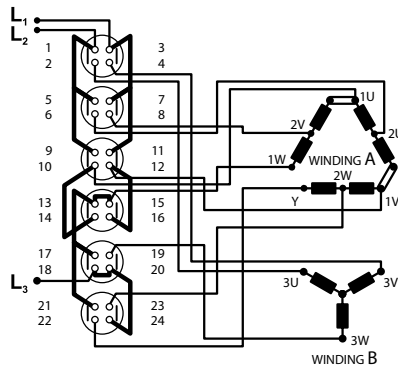

Diagram number

9554

Contact	0	1	2	3
1 - 2				X
3 - 4				X
5 - 6			X	
7 - 8			X	
9 - 10	X			
11 - 12	X			
13 - 14			X	
15 - 16			X	
17 - 18	X			
19 - 20				X
21 - 22	X	X		
23 - 24			X	

Pole change-over switch (O- Δ_A - Y_A - Y_B)



Identification on plate

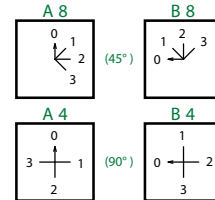

9555

Contact	0	1	2	3
1 - 2				X
3 - 4			X	
5 - 6				X
7 - 8				X
9 - 10	X			
11 - 12	X			
13 - 14				X
15 - 16				X
17 - 18	X			
19 - 20			X	
21 - 22	X		X	
23 - 24				X

Pole change-over switch (O- Δ_A - Y_B - Y_A)

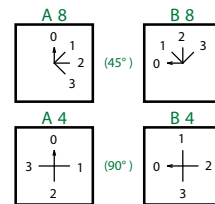
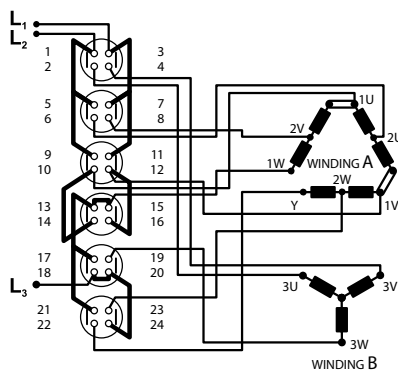

9556

Contact	0	1	2	3
1 - 2		X		
3 - 4		X		
5 - 6				X
7 - 8				X
9 - 10			X	
11 - 12			X	
13 - 14				X
15 - 16				X
17 - 18		X		
19 - 20	X			
21 - 22			X	X
23 - 24				X

Pole change-over switch (O- Y_B - Δ_A - Y_A)

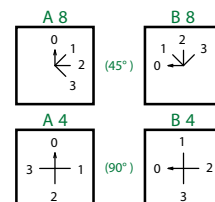
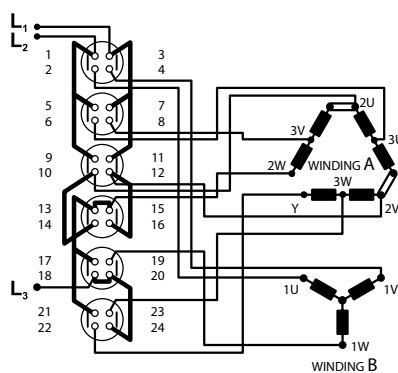
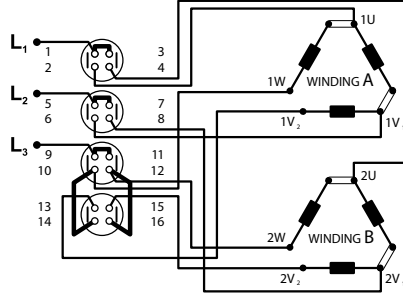

Diagram number

9553

Contact	0 1 2		
	0	1	2
1 - 2		X	
3 - 4			X
5 - 6		X	
7 - 8			X
9 - 10		X	
11 - 12			X
13 - 14		X	
15 - 16			X

Pole change-over switch 2 separate windings



Identification on plate

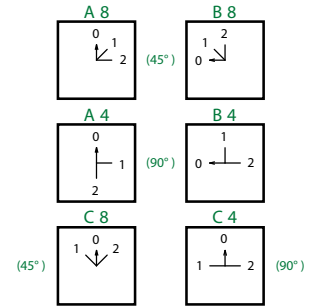

9557

Contact	0 1 2 3 4				
	0	1	2	3	4
1 - 2				X	
3 - 4					X
5 - 6		X			
7 - 8			X		
9 - 10				X	
11 - 12					X
13 - 14				X	
15 - 16					X
17 - 18		X			
19 - 20			X		
21 - 22				X	
23 - 24					X
25 - 26		X			
27 - 28			X		
29 - 30				X	
31 - 32					X
33 - 34		X	X		
35 - 36			X	X	

Pole change-over switch ($\Delta_A - \Delta_B - Y_A - Y_B$)

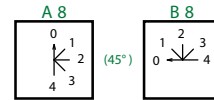
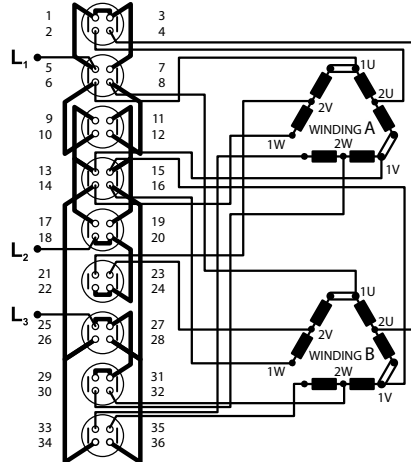

9567

Contact	0 1 2 3			
	0	1	2	3
1 - 2				X
3 - 4		X	X	
5 - 6		X	X	
7 - 8		X	X	
9 - 10		X	X	
11 - 12		X	X	
13 - 14		X	X	
15 - 16		X	X	
17 - 18		X	X	
19 - 20		X	X	
21 - 22				X

Pole change-over switch ($O - Y - \Delta - Y$)

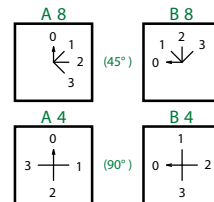
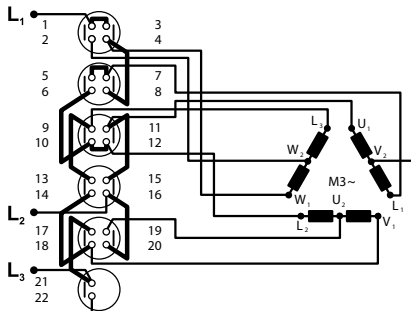

CUSTOM CAM SWITCH SPECIFICATION

Customer _____

Address _____

Company ID _____ Tax ID _____

Contact person _____ Fax _____

Tel. No. _____

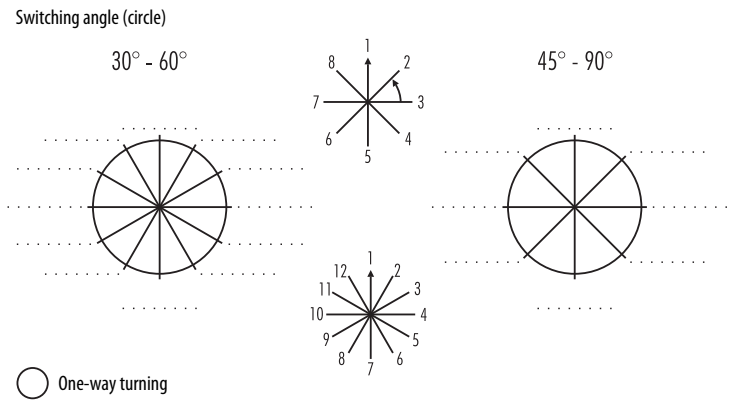

Date _____

The switch is intended for _____















Type range

VSR10 VSR16 VSR20

VSN10 VSN16 VSN20 VSN25 VSN32 VSN40 VSN63 VSN75 VSN80 VSN100 VSN125 VSN150 VSN250

            

Initial position - mark with arrow

Reverse movement - mark with arrow in direction of return (only for 45°)

45° a 90°: Recommended initial position 1 or 7, nevertheless, it can be placed in any marked position.

30°: Recommended initial position 1 or 10.

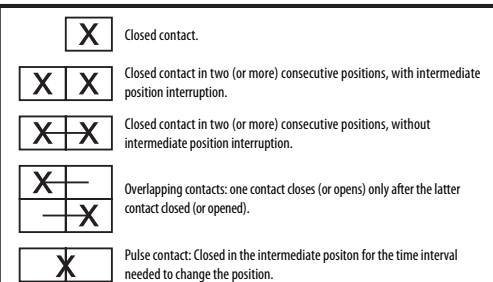
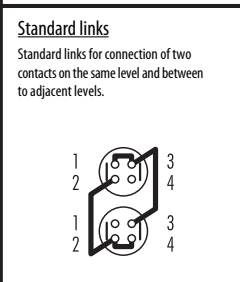

Allocation of controllers to front panels (for VSN 10 - 250 switches):

front panel \ controller	NM	NS	NO
AN	✓	✗	✗
PN	✗	✓	✗
PN/Z *	✗	✗	✗
HN	✗	✗	✓

front panel \ controller	NZS	KS	KO
AN	✗	✗	✗
PN	✗	✓	✗
PN/Z *	✓	✗	✗
HN	✗	✗	✓

* as a spare part only

Notes:

Contact number	Theoretical position identification											
	1	2	3	4	5	6	7	8	9	10	11	12
	Required position identification											
1 - 2												
3 - 4												
5 - 6												
7 - 8												
9 - 10												
11 - 12												
13 - 14												
15 - 16												
17 - 18												
19 - 20												
21 - 22												
23 - 24												
25 - 26												
27 - 28												
29 - 30												
31 - 32												
33 - 34												
35 - 36												
37 - 38												
39 - 40												
41 - 42												
43 - 44												
45 - 46												
47 - 48												

Accessories:

Diagram drawing number _____

Customer drawing number _____

OBZOR Production Cooperative Zlin

OBZOR is a stable and reliable supplier of products and services since 1965.

Traditional Czech producer of cam switches, house switches and sockets and other electrical accessories. A major supplier of plastic components for Automotive industry. The company has excellent machinery, also offers product assembly cooperation. Employer of physically challenged people.

The aim of the company is to constantly improve the quality, declared by following certificates: CSN EN ISO 9001:2009 and ISO 14001:2005.



Production Cooperative Zlin

Na Slanici 378
764 13 Zlín - Louky
Czech Republic

Phone: +420 577 195 138
Fax: +420 577 195 152
E-mail: export@obzor.cz

www.obzorzlin.com

