

Instructions Manual for Cam Switches VSN80, VSN100, VSN125, VSN150

The VSN80-150 series cam switches are tested as isolating switches suitable for safe isolating of electrical equipment; they are maintenance-free.

The cam switches must not be overloaded and the passing current must not exceed the specified thermal current without the cover (I_{th}). The VSN80-150 series switches are capable to switch on, switch off, and isolate safely the power circuits in machines and other devices.

In basic design, the switch body meets the IP 20 protection to connect the wires to all connecting terminals. In the case that wires are not connected to some connecting terminals, the wire port must be blinded by the packing provided as standard (item key 109651) to maintain the IP 20 protection for the switch.

The VSN switches provided with a coupler between the levels have blinded connecting terminals that are interconnected by the coupler. To remove the terminal caps, insert a screwdriver into the cut-out area and pull the cap to remove it. In the case the switch is provided with two jumpers on a single terminal, the wire cannot be connected to this terminal!

The IP 65 protection from the front will be met under the following conditions:

- The cam switch must be fitted with a seal on its shaft;
- The switch must be secured through the front mounting holes;
- Opening for the shaft and bolts will be drilled according to the drawing, which is included in the installation plan.

The cam switches of up to six levels can be secured from front through the front mounting holes or from behind through the rear mounting holes. The switches higher than 3 levels must be secured through the front as well as rear mounting holes. The switch is possible to be mounted on the DIN rail only if it has maximum of 3 levels.

The warranty period for the cam switch is limited by the number of switching cycles of electrical and mechanical durability, but not more than 60 months from the date of delivery. The cam switches meet the requirements of the CSN EN 60 947-1 and CSN EN 60 947-3 standards.

When selecting the cam switches for given external influences, we recommend to consult the designer.

Assembly procedure:

1. Secure the cam switches to the device through the front or rear sliding plate according to the switch type.
2. Connect the wires to the switch (maximum wire stripping length is 20 mm). If the maximum wire stripping length is exceeded or if unconnected terminals are not blinded, **the switch does not meet the IP 20 protection in these cases.** The connected wires must be lightened to avoid mechanical strain on the switch by the weight of the wires.
3. Check all the screws are tightened. The connecting terminal screws must be tightened to a specified tightening torque of 4 Nm. Failure to follow the specified torque can damage the switch!
4. Install a control and test the functions without load.

Installation must be carried out by a qualified electrician and the connection must comply with the relevant electrotechnical and safety regulations.

This product does not contain any hazardous substances. At the end of its life, it must be handled in terms of the applicable Waste Act, as amended.

Caution: Do not use the malfunctioning or damaged cam switch and secure it against use. The disassembly needs to be carried out by a qualified electrician. If the cam switch is not fitted with the control and the front plate, it must not be operated!



For further information on range of the cam switches, see the catalogue that can be found at www.obzor.cz. The printed catalogue can be requested by phone +420 577 195 151 or by email marketing@obzor.cz.

Cam switches technical data

Type range		VSN80	VSN100	VSN125	VSN150
Suitable for safe disconnection:		YES			
Impuls withstand voltage (U _{imp})		4 kV	4 kV	4 kV	4 kV
Isolation voltage (U _i)		690 V	690 V	690 V	690 V
Thermal current without cover (I _{th})		80A	100 A	125 A	150 A
Thermal current with cover 300 x 200 x 165 (I _{the})		80 A	100 A	125 A	63 A
Nominal on-load voltage (U _e) / Working frequency		400 V / 500 V / 50 Hz			
Working current (I _e)	AC 21	80 A	100 A	125 A	160 A
	AC 23	50 A	55 A	60 A	65 A
	AC 3	35 A	40 A	45 A	50 A
Short-term withstand current (I _{cw})		1 500 A / 1 s	2 000 A / 1 s	2 500 A / 1 s	3 000 A / 1 s
Short-circuit switching capacity (I _{cm})		1 000 A	1 500 A	2 000 A	2 500 A
Conductor diameter (mm ²)		25 - 70	25 - 70	25 - 70	25 - 70
Maximum number of switching positions		8	8	8	8
Maximum number of levels		6	6	6	6
Maximum number of contacts		12	12	12	12
Control shaft size (mm)		6 x 6	6 x 6	6 x 6	6 x 6
Electrical endurance in AC3 classes acc. ČSN EN 60947-3 chart A4		15 000	12 000	6 000	5 000
Mechanical endurance (number of cycles)		100 000	100 000	100 000	100 000
Maximum switching frequency / h		120	120	120	120
Connection screw		imbus no. 4			
Power dissipation (during max loading) per contact		7,2 W	9 W	11,3 W	13,5 W
Weather resistance (°C)		- 40°C to + 50°C			
Mounting position		any			
Maximum tightening torque		4 Nm			
Front mounting pitch		50 mm			
Max. length of conductor stripping		20 mm			

We offer technical assistance free of charge when selecting and ordering the cam switches – just call +420 577 195 153, +420 577 195 175.

INSTALLATION PLAN VSN 80 - 150

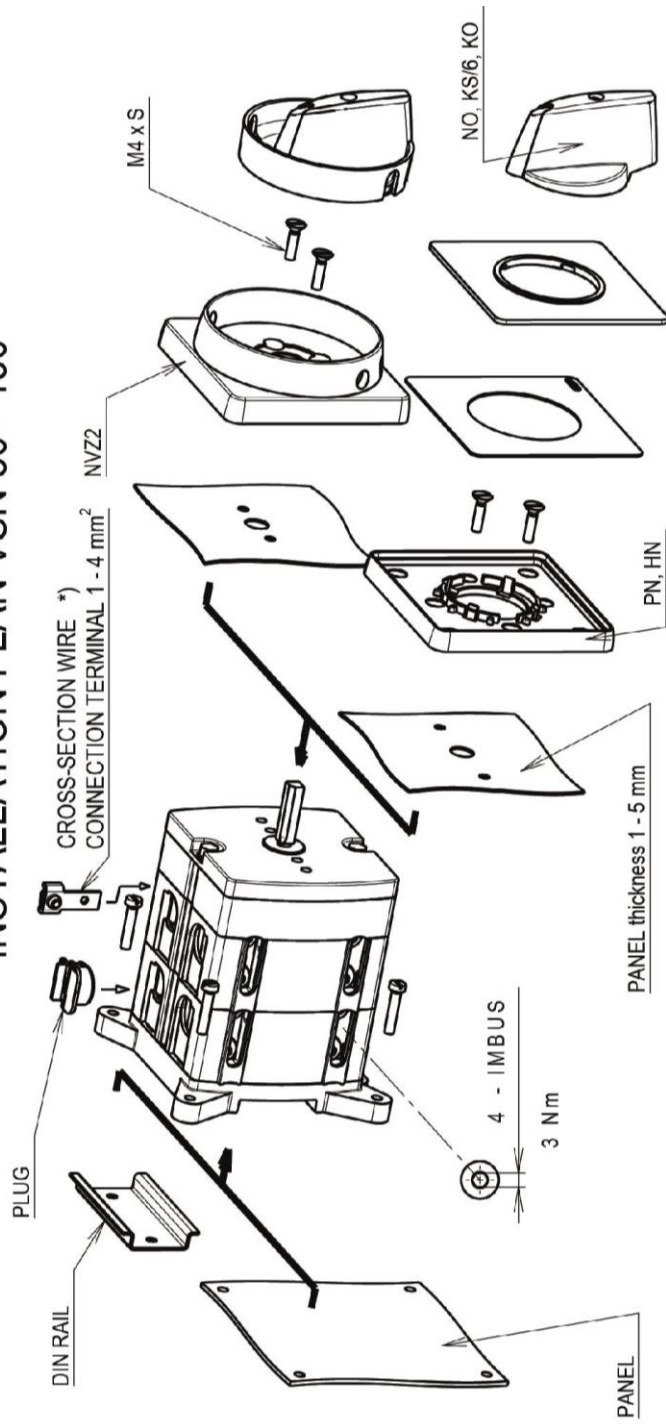

INSTALLATION PLAN:

FRONT MOUNTED - V

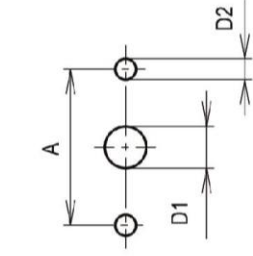

BACK MOUNTED - Z

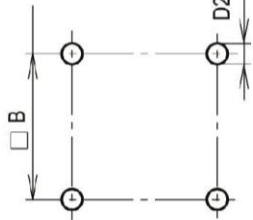

DIN RAIL - Z

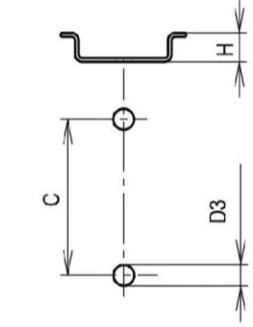

ALLOCATION OF CONTROLLERS TO FRONT PANELS

CONTROLLER	FRONT PANEL		
	NO	KS/6	KO
PN	X	✓	X
HN	✓	X	✓

RECOMMENDED SWITCHING LEVERS

FRONT PANEL	LOCKABLE EXTENSION	SCREW M4			BACK MOUNTED + DIN RAIL				
		A	D1	D2	S	PANEL	B	H	C
PN	50	10	4,3	14	1 - 5	86	7,5 - 15	50	8
HN	30								
NVZZ									

CONTROLLER	NUMBER OF LEVELS	
	VSN 80, 100, 125, 150	4-6
NO	✓	X
KS/6	✓	✓
KO	✓	✓
NVZZ	✓	X

DIMENSIONAL PLAN:

FRONT MOUNTED - V

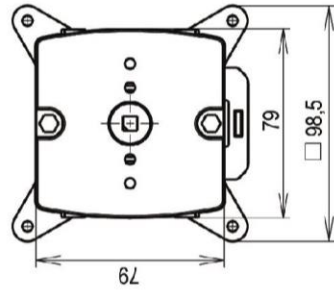

BACK MOUNTED - Z

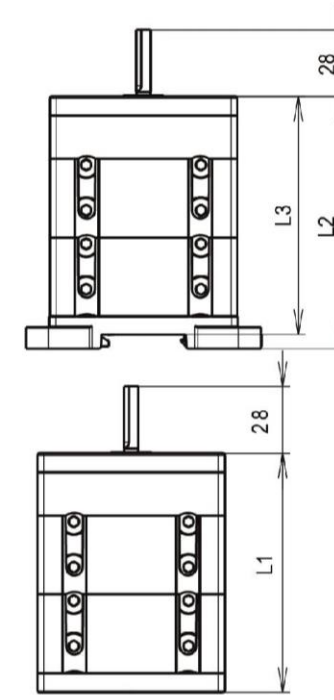

NUMBER OF LEVELS	L1	L2	L3
1	67	72,4	66,5
2	100	105,4	99,5
3	133	138,4	132,5
4	166	171,4	165,5
5	199	204,4	198,5
6	232	237,4	231,5

NOTE: dimension in mm

*) - only available as a spare part, not included with the switch